

**NATIONAL COMPETITION
REGULATIONS
OF THE
NEW ZEALAND FOUR WHEEL DRIVE
ASSOCIATION INCORPORATED**

**PART TWO
CROSS COUNTRY VEHICLE TRIALS**

2022



PART TWO

This booklet contains Regulations pertaining specifically to CROSS COUNTRY VEHICLE TRIALS.

SEE PART ONE of Regulations for Rules relating to:

- 1) Cross Country Vehicle Timed Trial
- 2) Competitive Safari
- 3) Cross Country Speed Event (Off Road Race)
- 4) Hill Rally
- 5) Teams Recovery
- 6) Cross Country Orienteering

DEFINITION OF A CROSS COUNTRY VEHICLE TRIAL

A Trial in which the marking for the event is mainly based upon the ability of Competitors to drive their vehicles over difficult terrain, including hill climbs, water courses, bogs, and side slopes, etc...

FURTHER COPIES OF THESE REGULATIONS

Maybe obtained from: The Secretary, Competition Committee, New Zealand Four Wheel Drive Association Inc.

Please forward \$20.00 per copy required, with Name and Address

OR

Download from www.nz4x4trials.co.nz

INDEX

| | | |
|-----------------|---|--------------|
| SECTION ONE - | Control of Events | Page 4 |
| | Organisation of Events | Page 4 |
| | Results | Page 5 |
| | Qualification for Finals | Page 5 |
| SECTION TWO - | Officials | Page 6 |
| | Recovery | Page 9 |
| SECTION THREE - | Safety | Page 10 |
| SECTION FOUR - | Entrance to Events | Page 14 |
| | Entry Rules | Page 14 |
| | Entry Form example | Page 16 |
| | Information Sheet Form example | Page 18 |
| SECTION FIVE - | Competitors | Page 19 |
| | Drivers and Co-Drivers | Page 19 |
| | Competition Licences | Page 19 |
| SECTION SIX - | Roll Cages / Roof Plates / Mandatory Rules all classes | Page 21- 29 |
| SECTION SEVEN - | Vehicle Classes | Page 30 |
| | Production Modified A & B | Page 30 |
| | Super Modified C & D | Page 33 |
| | Super Production E & F | Page 34 - 36 |
| | Production G | Page 37 - 39 |
| | Super Limited J & K | Page 40 |
| | Scrutineering Sheet | Page 41 |
| SECTION EIGHT - | Courses / Static Stops | Page 42 |
| SECTION NINE - | Competition | Page 45 |
| | Trial Rules | Page 45 |
| | Crew Rules | Page 46 |
| | Section Rules | Page 47 |
| | Scoring | Page 49 |
| | Points | Page 50 |
| SECTION TEN - | Protests and Appeals | Page 51 |
| SECTION ELEVEN- | Log Book Form example | Page 52 |
| | Competition Licence Form example | Page 53 |

SECTION ONE

1.1 CONTROL OF EVENTS

- A) The New Zealand Four Wheel Drive Association Incorporated, hereinafter referred to as NZFWDA shall arrange, control and manage Four Wheel Drive Competitions, and the National Championships, provided that the NZFWDA National Executive Committee, hereinafter referred to as the N.E.C, may delegate to any Sub Committee, the organisation of such Competitions, or the National Championships.
- B) The Sub Committees, when delegated by the N.E.C, shall approve and organise Competitions and the Zone Championships, provided that the Sub Committees may delegate to any Affiliated Club the right to organise any such Competitions, or Zone Championships.
- C) The Sub Committee shall post on the official Trials website the current copy of the Competition Regulations as soon as possible after each year's NZFWDA AGM.
- D) Amendments to these Competition Regulations may be made by the National Competitions Committee (here after referred to as the N.C.C) for safety reasons only, and notice of any such amendments shall be forwarded to all Sub Committees and Clubs at least 30 days before becoming effective.
- E) The Executive of the National Competitions Committee hereinafter referred to as "ENCC" shall be the final interpreter of these Regulations.

1.2 ORGANISATION

- A) The New Zealand Four Wheel Drive National Championships will be organised as a National Series.
 - a) The National Series will be run between 1st October till 28 days prior to the National AGM (held in May). The FINAL ROUND will be held in conjunction with the National Competitors Conference and AGM.
 - b) The ENCC shall decide which club and/or Sub Committee shall host the next year's Final Round.
 - c) The determination of the National awards and placings, will be at the Final Round of the National Series.
 - d) The ENCC shall collate requests from Clubs and or Sub Committees to host a round of the National Series which will be used to form a National Calendar.
 - e) The ENCC shall determine the number of trials from which eligibility for National and Zone placings shall derive, and the number of trials to be counted towards a National and Zone placing. This number and the National Calendar shall become official at the AGM and will be sent to the N.E.C., Clubs and all Competition Licence holders from the previous season.
- B) National Scorer shall determine National/Zone Championship awards and placings.
 - a) Clubs and/or Sub Committees wishing to host a National/Zone Series event shall apply in writing or email to the National Competitions Officer hereinafter referred to as NCO, as soon as possible but no later than 1st of May each year with a proposed date and alternative date for the next season.
 - b) The NCO shall determine which clubs and/or Sub Committees shall host National/Zone events and the dates of events.

- C) If agreement cannot be reached on who should host, or the date of any event, the ENCC shall make the final decision.
- D) Clubs and/or Sub Committees hosting National/Zone events shall organise and run them in accordance with these Regulations, and any Additional Supplementary Regulations (ASRs) issued for an event.
- E)
 - a) The National Series shall be controlled by the N.C.C, who will appoint the Stewards for the event, and may appoint other Officials as required.
 - b) The ENCC shall set up a Protest Committee to handle protests or problems that may occur during the National Series.
 - c) The Stewards and Protest Committee shall comprise members from outside the Host Club, however, the ENCC may call on a delegate from the Host Club to sit on the Committee.
- F) At least two months prior to any National/Zone event, the host club shall notify the Steward of time and place of course inspection.

1.3 RESULTS

- a) Any protests received regarding the addition of scores will be heard and finalised before the results are deemed the provisional results.
- b) These provisional results shall be double checked before the results are deemed the official results.
- c) The National Scorer shall post the official results online as soon as possible after each event.

1.4 QUALIFICATION FOR NATIONAL SERIES PLACINGS

- A) The ENCC shall determine the number of trials from which eligibility for National and Zone Championship awards or placings shall derive, and the number of trials to be counted towards a National and Zone placing.
- B) Removed at AGM 2018

SECTION TWO

2.1 OFFICIALS

- A) The following officials must be Affiliated Members of the NZFWDA: -
- a) The Clerk of the Course (must not be competing)
 - b) All Stewards (must not be competing)
 - c) The Scrutineers
 - d) The Chief Marshal (must not be competing)
 - e) The National Scorer

2.2 CLERK OF THE COURSE

- A) The Clerk of the Course is responsible for the following:
- a) All safety matters relating to the event, as well as notifying the Stewards of any near miss or accident that's occurs immediately
 - b) To ensure the safe operation of recovery teams and equipment
 - c) Ensure fire extinguishers are available and located in the correct locations, ensuring they have current certification as per section 3.1 Safety D. Ensure the locations of the extinguishers are marked with signage (Fire Extinguishers, Foam Spray) which are visible to competitors and officials.
 - d) Approval and positioning of First Aid personnel and Equipment.
 - e) Crowd Control.
 - f) Giving the Drivers' Briefing immediately before the start of the event.

2.3 STEWARDS

- A) The Stewards are to ensure the complete and accurate implementation of these Regulations and shall have the final decision on any matter within under the Stewards' jurisdiction.
- B) Course Inspection. The course shall be inspected by the Stewards at least one day prior to the event to check:
- a) Water section depth, and entrances and exits.
 - b) Colour, spacing and height of boundary pegs.
 - c) Number and positioning of gradings per graded section
 - d) Number, type and safety of observed section.
 - e) Length and drivability of timed sections.
 - f) Access to, and exits from observed sections.
 - g) Escape routes, if provided.
 - h) Ensure hazards are taped for spectator safety when applicable.
 - i) Ensure sections are taped for safety of all.
 - j) Ensure control of any water runoff from sections cannot get to waterways.
- C) Tie Breakers. Prior to the commencement of the event, the Stewards shall select at least five observed sections, including one timed section, to be used in order of selection to determine the winner of any placing should a tie eventuate for any placing.

Only the Stewards shall know which sections have been selected for this purpose

- D) Closing of sections. The Stewards shall inspect any section at which a serious accident has occurred, or which Stewards or the Clerk of the Course deem to be unsafe. All results for any sections so closed shall be null and void, and the section shall be deleted from the event. If a section is to be closed both Stewards need to make a joint decision to close that section. If only one Steward is available, then the Clerk of the Course can be used for the joint decision. If a joint decision cannot be made to close a section, then the third person needs to be involved meaning both Stewards and Clerk of the Course for a majority vote.
- E) Roll overs. The Stewards shall check all vehicles and competitors involved in roll overs of 90 degrees or more, **at the section BEFORE moving to another section orgoing to pits** to ascertain the safety of the vehicle and competitors before continuing in competition.
- F) Fires, All fires must be reported to the stewards and be inspected at the scene of the incident.

2.4 SCRUTINEER

- A) The Scrutineer shall have the final decision at vehicle scrutineering.
- B) The Scrutineer shall ensure that vehicles are checked for safety, soundness and eligibility.
- C) The Scrutineer shall ensure that scrutineering is carried out efficiently, thoroughly and impartially.
- D) If the standard, or eligibility of any vehicle, is in doubt, the Scrutineer shall call a meeting of all the ENCC present, to discuss and vote on whether or not the vehicle in question can pass scrutineering.

2.5 CHIEF MARSHAL

- A) The Chief Marshal shall appoint the Marshals and instruct them in their duties, and advise them on:
 - a) How to score sections.
 - b) How to mark score cards.

2.6 MARSHALS

- A) The Marshals shall be deemed “Judges of Fact” and shall:
 - a) Check that the sections are clear of vehicles and persons before instructing a competitor to start.
 - b) Check that all boundary and grading pegs are in position before instructing a competitor to start.
 - c) Replace boundary and grading pegs as necessary.
 - d) Observe the progress of the competitor throughout the section and determine any penalties incurred.
 - e) Fill in the points gained on the drivers’ and Marshals’ score cards, sign the cards, and check that the competitor has signed the cards.
 - f) Mark a “P” on both score cards in the event of a protest.
 - g) Mark a “R” on both score cards in the event of a rollover.
- B) Sector Marshals should be appointed to oversee groups of observed sections, and assist Marshals should any dispute arise, and to relay any necessary information to the Stewards or the Clerk of the Course. Clerk of the Course, Sector Marshals or Stewards cannot change the scoring of a section once it has started. Points awarded should not be changed unless a Competitor disputes them.

2.7 NATIONAL SCORER

- A) The National Scorer shall receive all score cards handed in by the competitors and the Marshals. Each driver’s score card shall be totalled when handed in, and the competitor shall sign the card as being correct.
- B) The National Scorer shall receive any protests, and pass these to the Protest Committee (ENCC).
- C) Marshal’s score cards shall be totalled and cross checked with driver’s score cards.
- D) The National Scorer shall oversee the tallying of all score cards, and the determining of the results of the event.
- E) The National Scorer shall ensure that the results are displayed at least half an hour before they become provisional.
- F) Removed at AGM 2018

2.8 PROTEST COMMITTEE

- A) The Protest Committee shall be the ENCC.
- B) The N.C.O or appointed delegate shall chair the Protest Committee, and may exercise a casting vote if necessary.
- C) ENCC may appoint other personnel to the Protest Committee.

2.9 RECOVERY

- A) All recovery operations shall be under the control of the Clerk of the Course.
- B) Removed at AGM 2018
- C) All equipment to be used for recovery shall be in good condition, and adequate for the purpose intended.
- D) Recovery Teams shall be sited by the Clerk of the Course, and methods utilised, and routes taken to recover stranded vehicles, shall be specified by the Clerk of the Course.
- E) Recovery vehicles must NOT enter observed sections, except in an emergency where it is necessary for the safety of any person, or when instructed to do so by the Clerk of the Course.
 - a) The Clerk of the Course shall only issue such instruction if all other attempts at recovery have failed, or for the safety of the competitors, officials, or the public.
 - b) The Clerk of the Course and the Chief Steward shall inspect any observed section where a recovery vehicle has entered the section and may close that section if the nature of the section has been noticeably changed by the recovery operation.
- F) The safety of competitors and the public is to be considered paramount during all recovery operations.

2.10 DESIGN SAFETY TEAM

- a) The design safety team shall inspect any roll cage or frame design that has been brought to the attention of the ENCC. Document differences from regulations, and report back to the ENCC with any recommendations. The ENCC will make the final decision on approval or otherwise.
- B) All roll cage failures will require inspection by the Design Safety Team who shall be elected at each Annual General Meeting of the NCC and who may make recommendations which will be incorporated in these regulations as a supplementary regulation until the change can be included in these regulations by the remit process.
- C) The design safety team maybe called upon to review safety concerns in the design of vehicles or specific changes required to accommodate specific competitors. They will document differences from regulations, and report back to the ENCC with recommendations. Any recommendations will be incorporated in these regulations as a supplementary regulation until the change can be included in these regulations by the remit process. If the supplementary regulation fails to be voted into these regulations, then it cannot be incorporated as a supplementary regulation for the following season(s).

SECTION THREE

3.1 SAFETY

- A) The Clerk of the Course shall be responsible for the safe running of the event and give every Marshal a copy of the *Safety Procedures for Marshals at National 4x4 Trials*, which can be accessed on the member's area on the website or on request from the Secretary.
- B) Organisers shall arrange for First Aid personnel and equipment to be available at all events from the start of the 1st section until all score cards are handed in at the end of the day.
- C) Organisers shall provide at least one Fire Extinguisher of 9.07kg (20lb) dry powder (or equivalent capacity of foam) at each section, or where sections are closely grouped, one extinguisher as above, shall be available at a point central to the group of sections.
- D) Crowd control barriers shall be erected where necessary, or as directed by the Clerk of the Course and/or Stewards'.
- F) **Instances of dangerous driving on access ways shall result in disqualification from the event.** When competitors vehicles at an event are being driven anywhere, and at any time on the property or adjacent accessways, no passengers shall be allowed to ride on the outside of the vehicle and all persons riding in the vehicle must have a minimum of the lap belt securely fastened.
The driver and co-driver are responsible for ensuring that they both have their helmet and seat belts securely fastened before commencing any and competitive sections of the event.
- G) All accidents involving any injury or head knock must be reported to the Clerk of the Course and Stewards, who shall investigate the cause, and take whatever action may be necessary to prevent further accidents.
- H) All events are to be run based on current Health & Safety Plans provided by ENCC. Host Clubs are required to submit their Health & Safety Plan (using template provided) for approval to ENCC at least two weeks prior their event. Copies are to be onsite on day of event.
- I) The ENCC shall have the power to stop events if there is an RMA breach, or, weather event that can cause fires, or, sediment runoff into waterways.
- J) The ENCC shall check the host clubs for an event under their control has all relevant paperwork for the RMA, and a paper trail from Regional Councils.
- K) The ENCC shall have the power to impound a vehicle after a serious accident. Until all parties have investigated that vehicle, then it will be released.

A) Protective Helmets shall be worn during all competition events and in All Classes, Protective Helmets shall:

- Comply with a current approved standard
- Be a snug fit on the wearer and must not be able to be removed by lifting the rear of the helmet (refer diagram below)
- Be in good condition, free of significant scratches and/or cracks.
- Not be modified, except as specifically permitted by the helmet manufacturer, standards body or the ENCC. In particular;
 - ABS and Polycarbonate helmets shall not be painted.
 - Composite shell helmets may only be painted with a paint approved by the helmet manufacturer.
 - Cameras shall not be attached to helmets by any means except where the camera forms an integral part of the helmet as provided by the manufacturer and the model of helmet is approved under one of the accepted standards.

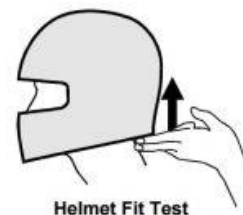

a) A Scrutineer or Steward may check helmets at any time during an Event.

B) Examples of the following approved helmet standards labels are detailed as below.

| | |
|--|--|
| <p>FIA: FIA 8860-2018* †† FIA 8860-2010* †† FIA 8860-2004* †† FIA 8859-2015* †† FIA 8858-2010* ††</p> | <p>SFI Foundation Inc: SFI Spec 31.1A* SFI Spec 31.2A* SFI Spec 31.1/2005* SFI Spec 41.1/2005 SFI Spec 41.1A SFI Spec 41.2A</p> |
| <p>Snell Foundation Inc: SA 2015* † SA 2010* † SAH 2010* †† SA 2005* † SA 2000* † M 2015 M 2010 M 2005 M 2000 CMR/CMS 2007 (Youth Helmet) K 2015 K 2010 K 2005</p> | <p>British Standards Institute: BS6658-85 type A/FR (red label), including all amendments † Valid for up to ten (10) years from date of manufacture, dependent upon condition.</p> <p>European Standard (R22): 'E' Mark 04 or 05 series Note: The series number is not the number in the circle. It is the number located close by, an example being; 05-12345.</p> |
| <p>Australian Standard: AS 1698</p> | <p>As well as: New Zealand Standard NZS 5430 Federal Motor Vehicle Safety Standard No. 218 Japan Industrial Standard T8133 ASTM F1952</p> |

Notes:

* denotes helmets also approved for use in International status Events.

† denotes helmets also approved for use with Forward Head Restraints (FHR) requiring the retro-fitment of tether posts.

†† denotes helmets fitted with tether posts by the helmet manufacturer / agent.

Recommendations:

- a) Helmets should be replaced at least every seven (7) years.
- b) Helmets (when not in use) should be kept in helmet bags.
- c) In the case of a severe impact the helmet should be destroyed.
- d) Foam neck braces may be used for the purpose of driver comfort, providing they are made entirely of fire-resistant material. If foam neck braces are to be used during the event, they must be worn throughout each section

3.3 FORWARD HEAD RESTRAINTS (FHR)

A) Forward Head Restraints are not considered mandatory under this Schedule, but where used shall:

- Comply with an approved standard.
- Be a good fit on the wearer.
- Be of the correct type/angle for the vehicle being driven.
- Be in good condition, free of cracks or signs of damage.
- Not be modified, except as specifically permitted by the manufacturer.
- Only be used with helmets bearing one (1) of the following standard markings:
 - FIA – 8860, 8859 & 8858,
 - Snell – SA 2015, SA 2010, SAH 2010, SA 2005 & SA 2000,
 - British Standard – BS 6658-85 A/FR, and
 - SFI – Spec 31.1/2005 & Spec 41.1/2005.

B) Approved Forward Head Restraint Standards: Examples of the following standards labels are detailed in 5.3 B).

- FIA – FIA8858-2002
- FIA – FIA8858-2010
- SFI – SFI Spec 38.1

C) Inspection: A Scrutineer may check Forward Head Restraints at any time during an Event for condition and correct use.

D) The use of a Forward Head Restraint (that helps restrict head movement in an impact situation whereby reducing the possibility of neck injuries) is highly recommended.

E) When using any Forward Head Restraint the mounting of the safety harness is critical. Shoulder straps should be 300mm to 400mm long and be as close as possible to horizontal (not more than - 20° downwards) (refer diagram 4.2

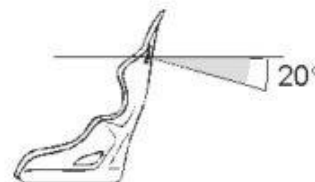

Diagram 4.2 - FHR Safety Harness Mounting Angles

Notes:

1. Compliant Forward Head Restraints are recognised by the applicable standards label.
2. FIA Technical Lists may be accessed at www.fia.com, SFI Foundation Spec 38.1 Compliant Device Manufacturers may be accessed at www.sifoundation.com
3. An information guide for the use of HANS® is published by the FIA, a copy of which may be accessed at www.fia.com

3.4 Fluid Safety

- A) All fuel tanks to be mounted in a safe and secure way
- B) Fuel filler hoses or extensions and caps are to be secure and not leak in roll overs. Use only fuel rated lines.
- C) All breathers fitted to fuel/oil tanks must not leak in a roll over. They must be set up correctly.
- D) All fuel pumps must be wired so that they can be shut down with the main battery kill switch. .
- E) All breathers on trans/gearboxes/powersteering etc must not leak fluids in roll overs.

SECTION FOUR

ENTRANCE TO EVENTS

4.1 ENTRIES

- A) Events will be open to four wheel drive vehicles only.
- B) Events will be divided into the following classes:
 - Class A - 0-4 cylinder production modified
 - Class B - 5 + cylinder production modified (exceeding 1300kg manufacturer's kerb weight for make & model)
 - Class C - 0-4 cylinder super modified
 - Class D - 5 + cylinder super modified
 - Class E - 0-4 cylinder super production
 - Class F - 5 + cylinder super production (exceeding 1300kg manufacturer's kerb weight for make model)
 - Class G - 0 + cylinder production
 - Class J - 0-4 cylinder super limited modified (2016)
 - Class K - 5+ cylinder super limited modified (2016)
- C) Multiple class entries will not be accepted.
- D) Vehicles must be entered in the class for which they are eligible.
- E) Vehicles must be entered by their correct make and model, e.g. Toyota - Landcruiser, Hilux, Blizzard, Suzuki - LJ50, LJ80, SJ410, SJ413, Vitara, etc., or Toyota Special, Suzuki Special, etc., or Homebuilt for vehicles completely built up and unable to be recognised by make.
- F) All vehicles will be checked at Scrutineering for all items (as applicable) listed on the Scrutineering Sheet, in addition to any other scrutineering requirements and must pass before being permitted to compete.
- G) All competitors must be affiliated members of NZFWDA.
- H) Organisers must check that all entries received for any event comply with 4.1 G)
- I) Entries will be confirmed in SWAN by a host club official upon receipt of entry fee. Competitors should ensure they receive confirmation of their entry (i.e. email from SWAN)
- J) Any entries not paid by closing date will be cancelled.
- K) Closing dates for receipt of entries for National and Zone Series Events shall be no earlier than 21 days before the event, and if possible, after the running of any prior zone event.
- L) Closing date for late entries for National and Zone Series Events shall be no earlier than 14 days before the event.
- M) The maximum entry fee to be charged for any National/Zone event will be as determined by General Meeting or postal ballot of competitors. Social and/or meal tickets not included. The Late Entry fee will be double the price of the standard entry fee.

- N) Scrutineers will use the checks on the Scrutineering Sheet as a minimum, to check vehicles for safety, soundness and eligibility.
- O) Rotary engines of a 0-2 rotor configuration will be deemed eligible for 0-4 cylinder piston engine classes, rotary engines of a 3+ rotor configuration will be deemed eligible for 5+ cylinder piston engine classes.
- P) Methanol is strictly forbidden, and any other fuel the burns without a visible flame.

4.2 ENTRY FORM

- A) The Official Entry Form, as on pages 12 and 13 of these Regulations, must be used for all National/Zone Series either in paper form or an electronic version



NZFWDA Competitions Committee

EVENT NAME: EVENT DATE:

EVENT TO BE HELD AT:
.....

HOST CLUB:
.....

POSTAL ADDRESS:

Cheques are to be made payable to:
.....

Entry Fee: \$ Closing Date for Entries:

Late Entry Fee: \$ Closing Date for Late Entries:

Late Entries may or may not be accepted, and may or may not be included in the Ballot for Numbers

Number of Meals required at \$ (Please include with payment)

DRIVER NAVIGATOR / CO-DRIVER

Full Name Full Name

Address Address

.....

Phone No (0) Phone no (0)

E-Mail (Notification can be sent to confirm entry received)

Vehicle Number:(your Licence Number)

Licence Number:.....

Club:..... Club:.....

NOTE: If the vehicle entered below is not owned by either of the above competitors, the owner's full name(s) must be supplied where indicated on the reverse of this form, and the owner(s) must sign this entry form.

Vehicle Make Model Year

Engine Make No.of Cylinders:..... CC Rating.....

Fuel Type: PETROL DIESEL LPG (circle)

Class Being Entered: A B C D E F G J K (circle)

NOTE: Eligibility for vehicle to compete in Class being entered, and compliance with vehicle regulations, will be checked at scrutineering. THE ONUS SHALL REST WITH THE COMPETITOR TO PROVE COMPLIANCE OR ELIGIBILITY.

Current NZ Drivers Licences, current NZFWDA Competition Licences and current Alternative Fuels Certificates (if applicable) and Log Books must be presented at Scrutineering.

MEDICAL CONDITIONS for Hosting Club and Medics to be aware of: (not Compulsory)
.....



INDEMNITY

It is ACKNOWLEDGED and DECLARED that it is a CONDITION of ENTRY to this event, that ALL persons having connection with the Promotion, Organisation, and/or the Conduct of this Event, including, but not limited to, the New Zealand Four Wheel Drive Association (Inc.), the Host Club(s), the Owner(s) and Lessee(s) of the Land, the Owner(s) and Lessees(s) of the vehicles, the Competitors, and all Officials, and others, are ABSOLVED FROM ALL LIABILITY arising out of any action or accident, causing property loss or damage, or personal injury, including death, howsoever caused, notwithstanding that such death, injury, loss or damage may have been contributed to, or caused by the negligence of the New Zealand Four Wheel Drive Association (Inc.), the Host Club(s), or by any of their respective Officials, Servants, representatives, agents, or by any other person.

DECLARATION

I DECLARE that I possess the standard of competence required for an event of the type to which this Entry relates, and that the vehicle in which I will compete is suitable, and properly equipped for the event, having regard to the course, type of terrain, and speeds which may be reached. I also declare that I/we will present our self for any alcohol limit testing if requested by the ENCC and hereby accept without question the results of the above said test.

UNDERTAKING

I UNDERTAKE that should I, at any time during this event, be suffering from any DISABILITY of any kind, whether permanent or temporary, which is likely to detrimentally affect my control of the vehicle, I will declare it to the Host Club Officials. Permission for me to participate, notwithstanding my disability, shall be given at the sole discretion of the Host Club.

The Host Club Reserves the Right to Accept or Reject any Entry Certification.

I CERTIFY that the details given on this Entry Form are correct, and I UNDERTAKE to inform the Host Club Officials of any change in these details, or alterations to the vehicle, which may affect the eligibility of myself, or the vehicle to compete in this event.

These items are to be checked by the competitor and initialled prior to signing indemnity:

| | |
|-----------------------------------|--|
| Roll Cage/Mounts/Welds | Body/Chassis (secure) |
| Tow Hooks/Front & Rear/HT Bolts | Seats (secure) |
| Seatbelts Approved Type (secure) | Crash helmet Approved Type/Condition |
| Foot Brake Operation | Brake Hoses and Pipes (no defects) |
| Steering Box/Rack System (secure) | Steering Joints and Hoses (no defects) |

We the UNDERSIGNED have read the pages of this Entry Form and the NZFWDA COMPETITION REGULATIONS and AGREE to be bound by them and any ADDITIONAL SUPPLEMENTARY REGULATIONS which are issued for this event.

SIGNED: Driver Navigator, Co-Driver

Vehicle Owner(s):..... Vehicle Owner(s) Name(s) (Print):

Where the Signatory to any of the above is **under the age of 18 years** the following consent shall be completed by his/her parent or guardian:

I (Full Name):

of (Address):

Being parent/guardian ofdo hereby consent to his/her participation in this event.

SIGNED

NOTE: Persons under the age of 15 years are NOT permitted to participate.

HOST CLUBS ACCEPTANCE OF ENTRY

Accepted By: Name:Position

Signed:Date:

4.3 INFORMATION SHEET - Organisers must supply information as detailed on this sheet either in paper form or an electronic version.

NZFWDA Competitions Committee INFORMATION SHEET



EVENT NAME:.....
EVENT DATE:.....

EVENT TO BE HELD AT:
.....
.....

HOST CLUB:
.....

POSTAL ADDRESS:
.....
.....

Held under the National Competition Regulations of the New Zealand Four Wheel Drive Association Inc., Part Two. It is essential that the competitors have a good understanding of the above Competition Regulations.

Event Officials:

Secretary:..... Phone No:

Email:

Scrutineer:.....Phone No:

Clerk of Course:.....Phone No:

ADDITIONAL SUPPLEMENTARY REGULATIONS

will not be issued herewith will be issued at Scrutineering (delete as applicable)

SCRUTINEERING will be held at:
.....

SCRUTINEERING ADDRESS:.....

On: from to

Onsite Camping will be available from:..... Onsite Camping will **NOT** be available.
(delete one line)

COURSE MAY BE INSPECTED ONfrom..... to

NO COURSE INSPECTION WILL BE AVAILABLE DUE TO
(delete one line)

DRIVERS BRIEFING : Will be held at am in the Pit Area.

THE EVENT WILL START at am

PRIZE GIVING will be held at:

Address: from

RESULTS will be displayed at approx:ASAP pm

MEALS/DRINKS will/will not be available from.....

MEAL TICKETS:Adults \$..... – Children 5-12yrs \$.....(under 5 yrs free)

Please note **numbers of meals required on your entry form, and include payment with your entry fee.**

SECTION FIVE - COMPETITORS

5.1 DRIVERS AND CO-DRIVERS

- A) All competitors entering National/Zone Series events must be Affiliated Members of the NZFWDA. Drivers must have conformation from club committee regarding driving standard.
- B) Drivers and Co-Drivers must hold a current NZ drivers licence and a current NZFWDA Competition Drivers Licence (DL). A non-driving Navigator must hold a current NZFWDA Navigators Licence (NL) but can't drive in trials. Emergency Navigators Licence is available (*with genuine reason and is only valid for the day of the trial applied for*). All Competitors must hold current NZFWDA Affiliation.
- C) If the co-driver is to drive in any sections, the co-driver must hold a current NZ drivers licence and a minimum of a NZFWDA Licence as above.
- D) All competitors must be fifteen years of age or older.
- E) All competitors must have a good understanding of the current Competition Regulations.
- F) Drivers must present a Current NZ Drivers Licence at scrutineering. Navigators need to have proof of age on identification presented at scrutineering.
- G) If diagnosed with concussion by onsite medical staff, you will have a 2 week stand down. You can get a Doctors clearance in writing to compete within the 2 weeks.

5.2 COMPETITION LICENCES

- A) Applications for Competition Licences shall be made on the form (example last page of rule book), to the N.C.C Treasurer, or other Official as appointed by the N.C.C, and all the details must be completed legibly. Copy of form will be available on official Trials website.
 - a) This form is to be used by:
 - New Competitors
 - Competitors under the age of 18 years
 - Competitors who do not own the vehicle they are competing in
 - Emergency Navigators Licences
 - b) Forms must be signed by the Driver, Co-driver, vehicle owner(s) (if neither the driver or co-driver) and parent or guardian of any of the aforementioned if under 18 years of age.
 - c) Competition License Renewals shall be completed online unless (a) applies
- B) Competition Licence fees shall be as set by a General Meeting.
- C) ***Navigators Licence Fees shall be half of the competition Drivers licence fee.***
- D) The N.C.C Treasurer, or other Official as appointed by the N.C.C, shall issue Competition Licences.
- E) The Competition Licence numbers shall be issued numerically as applications are accepted. You may retain the same number in consecutive seasons by reapplying before the expiry date of the licence. The number "1", "2" and "3" plate shall be reserved for the overall champion and must be displayed for the oncoming season.

- F) Competition Licences shall be valid during the season in which they are issued, and shall expire on the 30th day of September each year.

- G) All Drivers licences and Navigators licences will be double in price ***two weeks before rally***

SECTION SIX - MANDATORY VEHICLE REQUIREMENTS ROLL CAGES

All vehicles shall have roll cages constructed to comply with the following clauses 6.1 to 6.6.

6.1 CONFIGURATION

- (a) The general design shall be as in fig 1.
- (b) No part of the competitors anatomy shall protrude outside the confines of the bodywork or rollcage when viewed from the front or rear of the vehicle.
- (c) There must be at least **100mm clearance** between the top of the occupants helmets and the underside of the rollcage or roof plate, as per section 6.8 to 6.10. Someone of equal size may be used if navigator or driver are unable to attend scrutineering or they can be checked on the day of the trial.
- (d) Roll cages must have two longitudinal braces, one each side, from the roll cage towards the rear of the vehicle, shown as A to G and B to H in fig 1.
- (e) The fitting of diagonal bracing is compulsory. Such bracing must be made of the same material as the roll cage, and shall be fitted as infig 1. from either A to D or H or to any point between D and H, or from B to C or G or to any point between C and G. Two diagonal braces, conforming to this clause, may be used. *Alternatively* an A frame can be use in main hoop, with the top of the A in the centre of A-B, bottom legs can be between C-G and D-H or chassis mounted.
Also an A or centre support in front hoop can be used, this does not have to be roll cage material if the span of the front hoop is less than the maximum span as per 6.2 MATERIALS. If different diameter tube is used, the load points on the main frame must have some sort of load spreading. (Small diameter tube will punch through bigger diameter tube)
- (f) In space frame vehicles, where the roll cage is part of the vehicle frame (i.e. there is no chassis) the principles of these Regulations shall be adhered to.

6.2 MATERIALS

- (a) Roll cages shall be constructed from Grade 250 medium wall black pipe made to BS 1387 – 1985 specifications.
- (b) The size of the pipe to be used is to be determined by the overall weight of the vehicle and unsupported span as below. Overall weight is based on the vehicle being competition ready. Competition ready includes a full tank of fuel and with appropriate levels of fluids in diffs, engine, transfer case, gearbox/trans and coolers.
 - vehicles up to 1000kgs - minimum 25mm nominal bore; maximum unsupported span of 1200mm
 - vehicles over 1000kgs up to 1500kgs - minimum 32mm nominal bore, maximum unsupported span of 1400mm
 - vehicles over 1500kgs up to 2000kgs - minimum 40mm nominal bore, maximum unsupported span of 1600mm
 - vehicles over 2000kgs - minimum 50mm nominal bore, maximum unsupported span of 1800mm
- (c) maximum unsupported span must be adhered to regardless of vehicle weight i.e. If spanning more than the maximum unsupported span permitted by these regulations then a larger appropriately sized pipe must be used. Span is measured from outside to outside or overall length.
- (d) All mounting bolts will be a minimum 10mm (3/8") diameter high tensile steel.
- (e) Heavy wall black pipe made to BS 1387-1985 specifications may be used as roll cage pipe.

6.3 JOINTS

- (a) All joints must be welded where possible.
- (b) Joints in the main structure are not recommended, and should be avoided.
- (c) If it is necessary to make a joint in the main structure, then the joint must be sleeved to prevent shearing of the joint. Internal sleeves must extend at least 10mm either side of the joint to prevent shearing.
- (d) Where removable connections are incorporated in the roll cage, they must comply with 6.3 (e), (f) or (g).
- (e) Where clamps are used, they must be secured through with high tensile bolts to resist sliding.
- (f) Muff connections as in fig 2 may be used.
- (g) Tongue and gusset connections as in fig 3 may only be used in the diagonal brace, and must be made from a minimum of 6mm plate. Bolts used to secure such joints must be minimum 12mm diameter high tensile.

6.4 MOUNTINGS

- (a) All mounts to chassis or frames, must have a minimum mount area of 100 sq cms (16 sq inches) per mount of minimum 3mm plate and must be secured by a minimum of four 10mm (3/8") high tensile bolts per mount.
- (b) Where roll cage is welded to the chassis, pipe must be gusseted to a minimum bearing area of 100 sq cms (16 sq inches) per mount.
- (c) Where roll cage is mounted to the body, the roll cage must be welded to minimum 3mm thickness plates with a minimum area of 232 sq cms (36 sq inches) per plate. The plates must be attached to the body panels with a minimum of four bolts or cap screws of minimum 10mm (3/8") diameter per plate.
- (d) Where roll cage is mounted to body panels, backing plates (of minimum thickness of 3mm) must be used. Backing plates must be of similar size and shape, but not exactly the same size as the mounting plates, in order to prevent a punching through effect.
- (e) Where roll cage is mounted to the body the main hoop must be chassis mounted as per 6.4 (a) or (b) if the original body panels do not provide sufficient structural support.
- (f) Any rubber mount used in the roll cage shall be enclosed by a steel case to prevent shearing of the mount as in fig 4.
- (g) Twin lug connections as in fig 4 with axis working under double shearing conditions may be used, but not on main hoop. Bolt size for this type of connection must be minimum 12mm diameter high tensile.

6.5 FABRICATION

- (a) No part of the structure shall show evidence of crimping, wall failure, or section weakening.
- (b) Bends should be of a smooth and continuous nature.
- (c) All welds shall be of the highest possible quality with maximum penetration, using either tig, mig or arc welding.
- (d) An inspection hole of 3mm diameter may be drilled by the scrutineer at any point in the roll cage they choose to verify the correct pipe thickness. Only one hole may be drilled and will be used for subsequent inspections unless the roll cage has been modified after its original inspection in which case another hole may be drilled. After the first inspection competitors may seal this hole with a rivet or bolt and only remove if requested by the scrutineer for inspection.
- (e) All tubes to be as straight as possible between structural bends as per fig 1.

6.6 COMPLIANCE

- (a) Any vehicle fitted with a roll cage that does not comply with these regulations will not be eligible to compete unless the design safety team has checked the cage, documented the differences to these regulations, and indicated they are satisfied the design and construction are satisfactory.
- (b) If any of the pipe that forms the roll cage structure as in FIG1 – Roll Cage General Design, is bent out of line, because of impact, by more than the OD of the pipe and cannot be straightened, repaired or replaced without showing signs of damage or crimping then that vehicle will be deemed unable to continue in competition until it has been satisfactorily been repaired and passes scrutineering again.

6.7 SAFETY

- (a) The Executive Committee has the power to elect a Sub Committee to review safety aspects of Roll Cage design, reviewing consistent faults or associated design faults that will have an impact in the future, and report back with new designs, being aware of the changes within the sport of vehicle design and section design.

ROLL CAGE DESIGNS

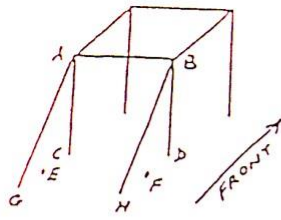

FIG 1
Roll Cage General Design

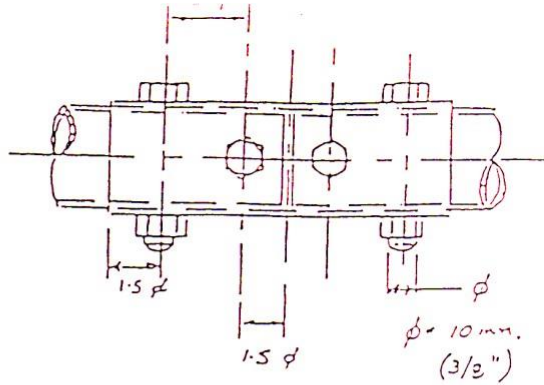

FIG 2
Muff Connection

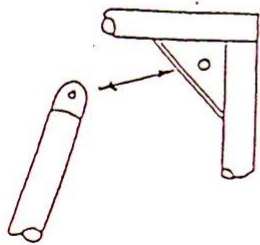

FIG 3
Tongue and Gusset Connection

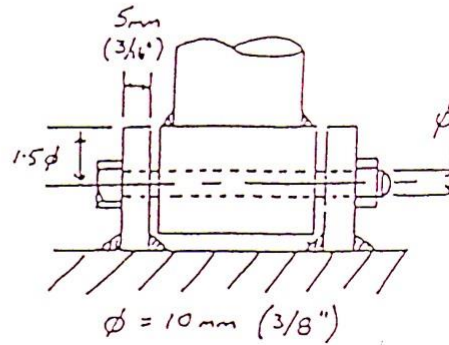
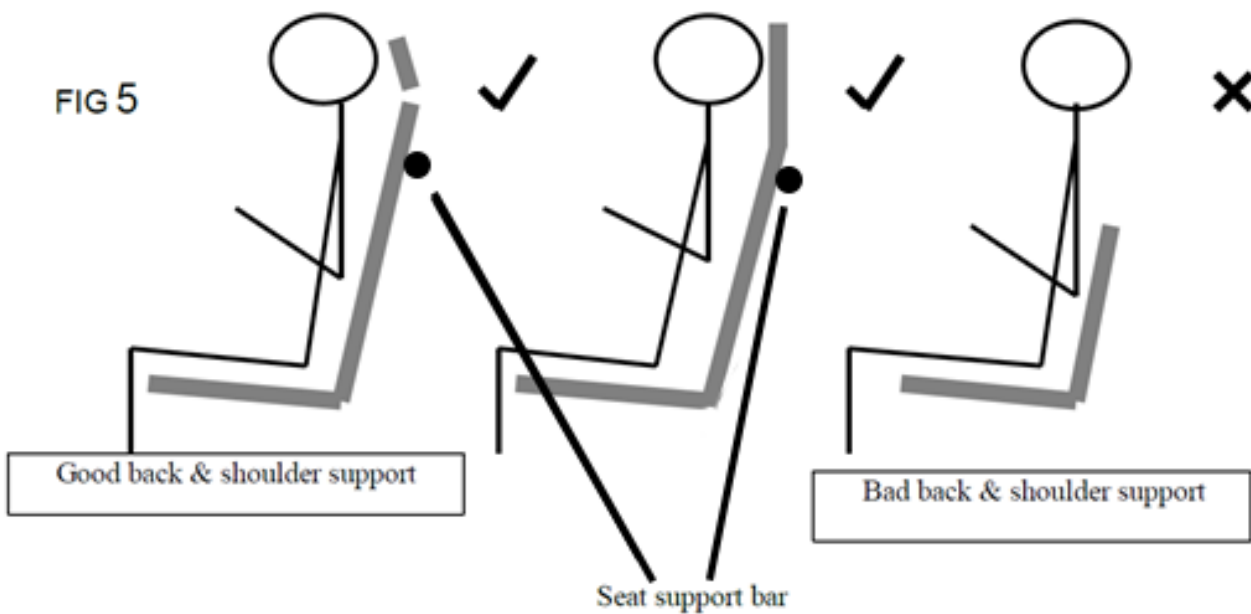

FIG 4
Twin Lug Connection



ROOF PLATE

(NEW as per DST recommendations May 2016 and introduced due to safety concerns around compression injuries)

6.8 All vehicles must have a roof plate that complies with the following:
See diagrams on following pages for examples.

- (a) Support structure measurements and tolerances. Support structure must be constructed from the same material as the roll cage (refer section 6.2).
- Distance from centre of helmet to centre of front support bar is 250mm plus or minus 25mm. (225mm to 275mm are the limits)
 - Distance from centre of helmet to centre of support bars either side of helmet are 200mm plus or minus 25mm
 - Distance from centre of helmet to centre of support behind must not be more than 200mm. If main roll cage exceeds this then a separate support bar must be added
- (b) A 6mm hole to be drilled near a corner of the plate (for thickness confirmation).
- (c) Some folding or shaping of the outer edges of the roof plate may be required to achieve these welds. These above limits should be kept in mind while completing this work.

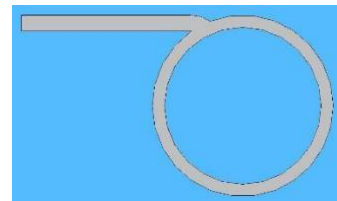
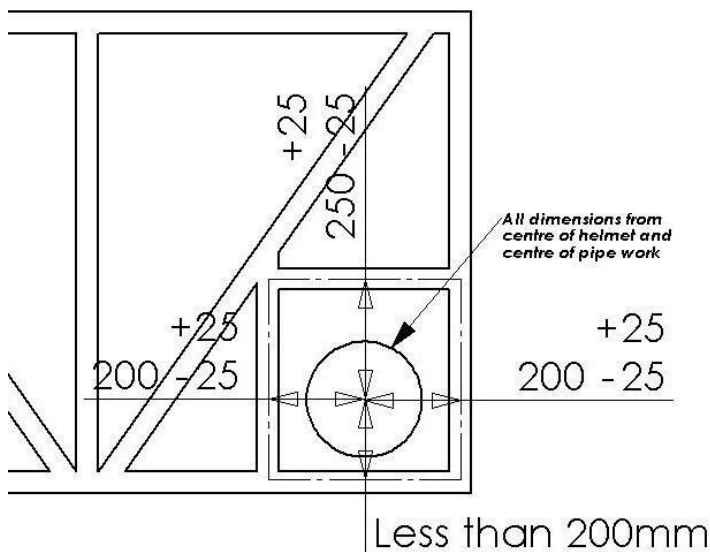

- Roof plate fully welded around edges
 - Top of plate no lower than top of pipe
- OR

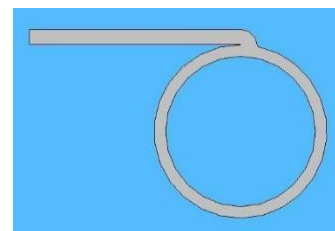

- Roof plate fully welded around edges
- Bottom of plate no higher than top of pipe

6.9 **Head Position:** is defined as the position in which an occupant's head comfortably rests when the occupant is fully belted into the vehicle with the back of the helmet resting comfortably on the seat's head rest. This resting head position shall also remain completely protected by the vehicle's roll cage. When moving the head forward from this position, 100mm of head clearance between the top of the helmet and the underside of the roof plate and/or any part of the roll cage shall be maintained at all times.

6.10 Based on the fully welded arrangement noted, the **thickness requirements** for the different roll cage specifications are as follows:

- Up to 1000kg (minimum 25NB cage) 3mm steel plate
- 1000kg to 1500kg (minimum 32NB cage) 3mm steel plate
- 1500kg to 2000kg (minimum 40NB cage) 5mm steel plate
- Over 2000kg (minimum 50NB cage) 5mm steel plate

PROTECTIVE ROOF PLATE DESIGN DIAGRAMS (reference only)

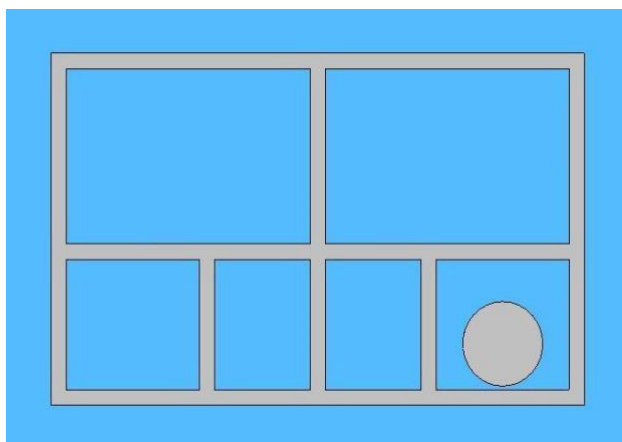

Acceptable

Area above helmet protected, 250mm forward, 180mm to side bar, 200mm toward centre of vehicle

100mm clearance between top of helmet and underside of roof plate

Measurements are horizontal only, taken from vertical centre axis of helmet

Acceptable

Again area above head protected, 250mm forward, 225mm to side bar, 200mm toward centre of vehicle. Diagonal intersects area but remains 200mm clear of helmet

100mm clearance between top of helmet and underside of roof plate

Measurements are horizontal only, taken from vertical centre axis of helmet

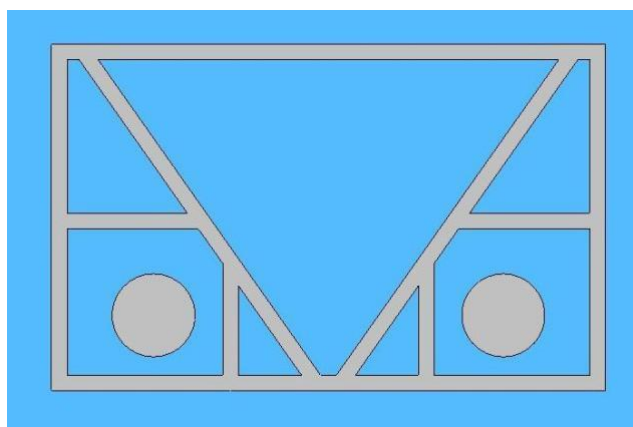

Acceptable

Again area above head protected, 250mm forward, 200mm to side bar, 200mm toward centre of vehicle. Diagonal intersects area and is acceptable as long as...

100mm clearance between top of helmet and underside of DIAGONAL BRACE

Measurements are horizontal only, taken from vertical centre axis of helmet

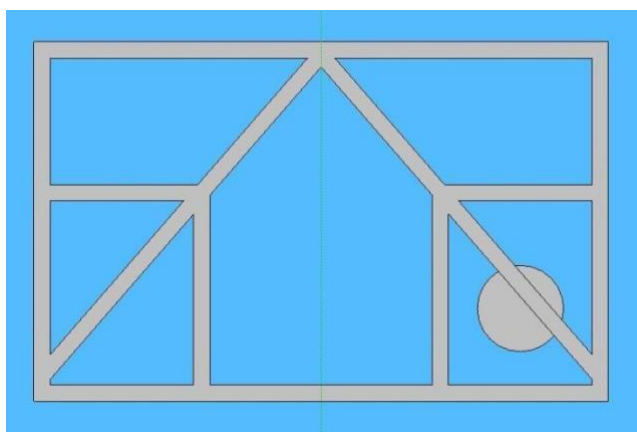

Unacceptable

Insufficient area above head protected, 250mm forward, 250mm to side bar, 200mm toward centre of vehicle. Diagonal intersects area but is less than 200mm clear of helmet

100mm clearance between top of helmet and underside of DIAGONAL BRACE

Measurements are horizontal only, taken from vertical centre axis of helmet

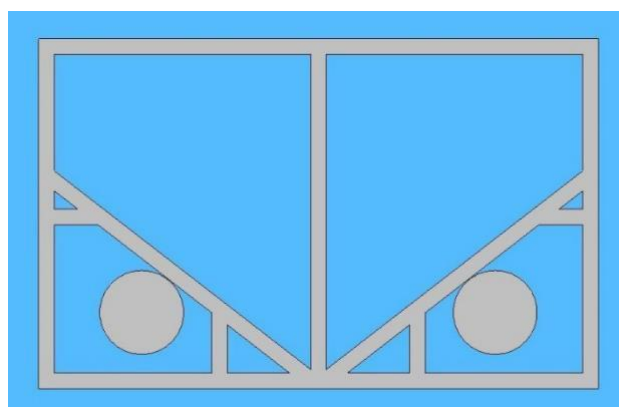

Acceptable

Again area above head protected, 250mm forward, 220mm to side bar, 220mm toward centre of vehicle. Diagonal intersects area but remains 200mm clear of helmet. Rear cage more than 200mm behind helmet so extra support added

100mm clearance between top of helmet and underside of roof plate

Measurements are horizontal only, taken from vertical centre axis of helmet

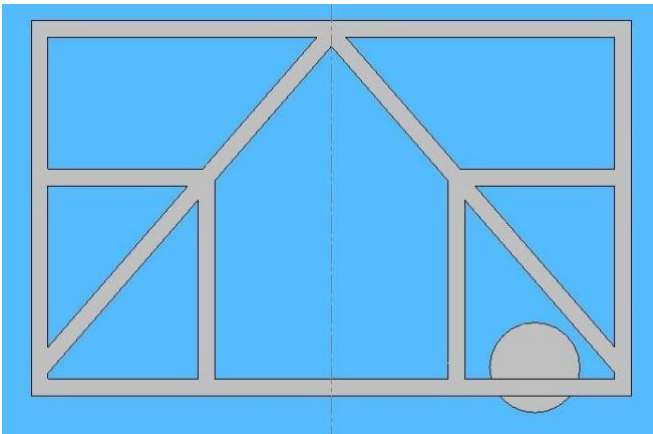
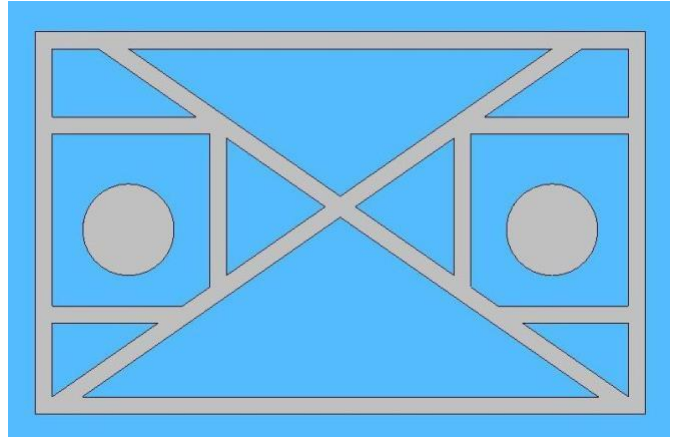

Unacceptable

Helmet is not within the confines of the protective roof plate

100mm clearance between top of helmet and underside of DIAGONAL BRACE

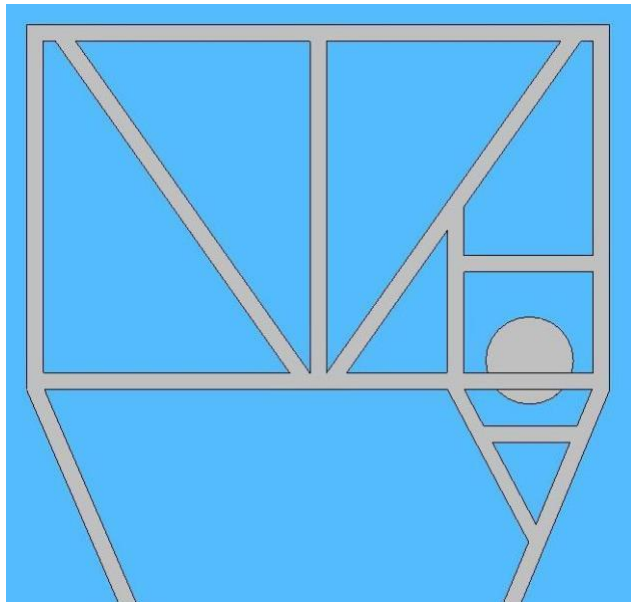

Acceptable

Where the above occurs, more framing and extension of the roof plate behind the rear hoop will need to be added, as shown.

100mm clearance between helmet and underside of Roll Cage.

6.11 – **All vehicles must have the following:**

- a) A roll cage and roof plate that complies with Section 6. Vehicle modifications required to install a roll cage compliant with Section 6 shall be allowed, e.g. holes through the floor.
- b) Seat belts for driver and co-driver.
 - i) A full harness seat belt with a 4 point mounting is the minimum requirement. Seat belts must be a factory made harness system providing over shoulder and thigh restraint and crutch (minimum of 5 belts), with a single clasp (preferably of lever action). Seat belts must be in good condition i.e. no signs of damage in seat belt material such as significant sun fading/hardness, cuts and fraying. Seat Belt mounting points to be as per the belt manufacturers recommendations for the seating position adopted and must be worn correctly. Onus is on competitor to provide documentation to support
 - ii) Seat Belt mounting points to be as per the belt manufacturers recommendations for the seating position adopted. Onus is on competitor to provide documentation to support.
 - iii) The use of inertia reel type seat belts is forbidden
- c) Hand grips for navigator/co-driver must be fitted within the confines of the roll cage and body.
- d) Crash helmets for driver and co-driver.
- e) Tow Hooks securely fitted with a minimum plate thickness of 6mm to the front and the rear of the chassis of the vehicle. Tow balls will not be permitted.
- f) Two operable fire extinguishers of not less than .9kg (2lb) each Dry Powder and must be securely mounted in an accessible place. The fire extinguisher's gauge must read in the green, the extinguishers must be in good condition and have a five year statutory pressure test service life. . And the extinguishers shall be visible from outside the vehicle OR a Fire Extinguisher sticker (Red and white, minimum 70mm wide, 100mm tall) be applied to the panel that the extinguishers is behind
- g) Fuel tight caps fitted to all fuel tanks.
- h) Two throttle springs fitted, with at least one to the carburettor butterfly shaft, unless fuel injected, then only one spring needed as supplied by manufacturer.
- i) **WHEELS**
 - i) Competitors may present for scrutineering, any number of sets of rims with tyres fitted, and so long as these pass scrutineering, shall compete on one set (four rims and tyres) selected prior to the start of the event.
 - ii) Changes to the selected set will only be permitted if tyre is punctured or the rim is deformed and only the damaged wheel may be changed.
- j) A bonnet which completely covers the engine bay (bonnet scoops and side ventilation permitted).
- k) Adequate firewall and floor panels, etc. to protect the occupants from engine, running gear, and the ground.
- l) If operating on, carrying LPG, a current Alternative Fuel System Certificate of Fitness, which must be presented at scrutineering.
- m) An efficient muffler, or spark arrestor.
- n) Lubricants in gearboxes, transfer boxes, and differentials. Any type of lubricant may be used.

- o) Foot restraints at no less than 100mm from floor to be fitted, or incorporated into body design.
- p) Seats must be mounted securely as per manufacturer recommendations and be in good condition. Back and head must be supported by either full back or combination high back seat and head rest as in fig 5, p23. There must be a support bar spanning the main hoop behind both seats to be positioned above $\frac{3}{4}$ of the height of the seat this must make contact with the rear of the seats. An equal structure for the support of the rear of the seat may be used but must satisfy the national scrutineers that it will do the same job.
- q) A main hydraulic braking system, working on all four wheels when foot brakes are applied.
- r) Flexible brake lines shall be used where required and are to be anchored as per recognised automotive standards

6.12 - All vehicles MAY have the following:

- a) Any of the following fuels: Petrol, Diesel, or LPG. If LPG is used, or carried, the system must have been installed by an Authorised Person, and must comply with the requirements of each class as to carburettor venturi number and size.
- b) A protective bulkhead, or partition between any fuel tank and the driver/co-driver compartment, sufficient to prevent the passage of flame or liquid. While not mandatory, it is strongly recommended that such protection is fitted.
- c) A spare wheel, if carried must be securely mounted.
- d) Dive bottles, or similar apparatus. If carried these bottles must be securely mounted, and must run through a regulator with the output pressure set to a maximum of 150 psi, and only an inert (non-inflammable) gas may be used.
- e) Snorkels fitted to the air intake.
- f) All blinkers, headlights and tail lights may be removed.
- g) A parking brake, independent of the main hydraulic braking system, capable of holding the vehicle at rest on a grade of 1 in 5.
- h) Beadlocks
- i) Tubes fitted in all tyres to be used in competition

6.13 - All vehicles MUST NOT have the following:

- a) Exposed exhaust systems fitted in such a manner as to be likely to cause injury or burns.
- b) Radiators, fans, or drive belts mounted on the roll cage, or in any other exposed position on the vehicle so as to be capable of causing injury to any person.
- c) Mud guards, or any other part of the body, with sharp outer edges, or other protrusions which could cause injury.
- d) Any loose, or insecure equipment, parts, or tools.
- e) Any loose mats, insulation, interior panels, or trim.
- f) Agricultural tyres. An agricultural tyre is defined as any tyre, not legal for road use or speed rated for less than 30 Kph, having the clearance area exceeding 58% of tread area at 6 psi.
- g) Tyre tread patterns intentionally altered in any way.
- h) Chains, or tyres spikes.

SECTION SEVEN - VEHICLE CLASSES

7.1 PRODUCTION MODIFIED VEHICLES - CLASSES A AND B

Following the 2007 AGM, all vehicle class rules can only be changed by remit every third year.
ie: 2022, 2025, 2028

- A) A production Modified Vehicle is as it leaves the master distributor's factory, and must use original equipment and parts for the vehicle make, and model, except as expressly permitted, or disallowed, in the requirements of this Section 7.1.
- B) Production modified vehicles must exceed fifty fully built up units of the same make and model or public sale by the master distributor.
- C) Any competitor who deliberately enters a Production Modified Class Vehicle with any modification other than permitted in these Regulations, will lose all points gained, and be banned from competing in the rest of the Series.
- D) In all cases of any doubt, or dispute arising regarding the compliance of any vehicle with these Regulations, or the eligibility of any vehicle for any class, the onus shall rest with the competitor and/or vehicle builder to prove compliance, or eligibility.
- E) If required, the competitor must supply a set of factory specifications for the vehicle make, model, and year, for Production Modified vehicles.
- F) Compliance with section 6, MUST have requirements.
- G) Compliance with section 6, MAY have requirements, and:
 - i) Factory gauges and gauge panels can be replaced provided replacements fit within the original factory dash.
- H) Compliance with section 6, MUST NOT have requirements.
- I) BODY
 - a) On all vehicles the top may be removed i.e.: roof, side panels, pillars, tops of doors, windscreen, and all glass down to the height of the windscreen base or to no lower than it left the Master Distributors factory as a soft top body. Where the body has been cut for the top to be removed, it shall be made safe by welding in covers to eliminate all sharp edges.
 - b) On all vehicles in addition to the above, tailgates, spare wheel carriers, footstep assemblies, rear seats (including belts), upholstery, trims (including bodywork used to mount trim e.g. flares & sills) and factory built roll bars may be removed.
 - c) Bumpers and bumperettes may be lightened, altered, replaced with aftermarket bumpers or replaced with a rear bar.
 - d) Front (bull) rear, or side bars may be added, but must be to WOF standard.
 - e) Standard seats may be added.
 - f) The body may be modified to allow the installation of any engine, gearbox, or transfer case, provided that floor and bulkhead/firewall panels are complete.
 - g) Original doors may be replaced with non-standard doors, or removed.
 - h) The bonnet may be modified to improve engine cooling, but must completely cover the engine bay.
 - i) Any modification to the wheel arch and inner guards (front and rear) can be made provided some form of inner guard made from similar material is in place and that it is ONLY done for tyre clearance. With no sharp edges left that can cause harm.

- j) Panels made from materials not used in production assembly may be used provided the panels equal or exceed the original panel weight, and conform to the original design and shape, and it is proved that either:
- i) The body panels concerned are no longer available, e.g. Gipsypanels.
 - or
 - ii) The body panels concerned are less expensive than the original panel.

The panels concerned can be one piece design, eg. One piece fibreglass bonnet, guards and front grill.

- k) An area below the "B" pillar (top front corner) next to the seats may have up to 50cm² removed for occupant safety only. For example a triangle removed that is 10cm horizontally from the top corner of the panel to 10cm vertically below the top panel.

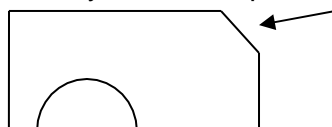

J) CHASSIS

- a) The chassis may only be modified to allow for front tyre clearance, or for changing independent differential assemblies, engine or gearbox/transfer case mounts, and such modifications shall be only those required to install another independent differential assembly, engine, gearbox or transfer case or to allow tyre clearance.

K) DIFFERENTIALS

- a) Production modified vehicles may not have any form of locking devices or limited slip etc. in differentials or on axles, whether factory fitted or aftermarket.
- b) Differentials may be internally modified, and axles changed.
- c) Anti sway/roll bars may be removed from differentials.
- d) Vehicles with independent suspension may replace standard independent differential assemblies with any brand of factory made independent differential assemble, provided the suspension is not altered in any way.
- e) An inspection hole of no greater than 75mm may be added to factory differential housings both front and rear.

L) BRAKES

- a) Production Modified vehicles may fit brake boosters, tandem master cylinders, and/or disc brakes to the original brake system.
- b) (**Not in effect till 2022-2023**) Independent wheel brakes may be fitted either to the front or rear of the vehicle but not both.

M) CLUTCH

- a) Clutch plates, pressure plates, and release bearings may be replaced with aftermarket clutch parts.
- b) Clutch cables may be replaced with hydraulic clutch operation systems.

N) SHOCK ABSORBERS

Production modified vehicles may fit heavy duty shock absorbers provided they are fitted to the original mounts, and equal the number of shock absorbers that were factory fitted.

O) SPRINGS

Production modified vehicles may fit shackle stops, and overset springs may be used, provided they conform to the original design.

P) RIMS

Production modified vehicles must use rims which are no wider than eight inches, and not more than sixteen inches in diameter.

- a) Track of wheel may be altered.
- b) Wheel spacers may be used

Q) TYRES

A Class - Maximum tyre size for Production Modified Vehicles will be 31" x 12.5" or metric equivalent as per manufacturers specifications or as marked on tyre wall.

B Class - Maximum tyre size for Production Modified Vehicles will be 33" x 12.5" or metric equivalent as per manufacturers specifications or as marked on tyre wall.

R) FITTINGS AND ACCESSORIES

The following items may be removed: emission control equipment, wiper arms, screen and headlamp washers, rear vision mirrors, sun visors, heaters and ducting, air conditioning, horns, clocks, radios, cigarette lighters, ash trays, centre consoles, cabin lights, inside door handles, window winder mechanisms, all associated wiring and window wiper mechanisms.

S) Production Modified Vehicles may have any form of modification to, or transplant of the following:

- a) Engine
- b) Gearbox and/or transfer case
- c) Ignition System
- d) Fuel System
- e) Steering, except four wheel steering and orbital steering
- f) Exhaust
- g) Cooling System (Any form of modification can be made to the cooling system as long as the radiator remains securely mounted anywhere under the confines of the bonnet)
- h) Drive Shafts

7.2 **SUPER MODIFIED VEHICLES - CLASSES C AND D**

Following the 2007 AGM, all vehicle class rules can only be changed by remit every third year.
ie: 2022, 2025

- A) Compliance with section 6, MUST have requirements.
- B) Compliance with section 6, MAY have requirements, and:
 - i) Vehicles may have mudguards
- C) Compliance with section 6, MUST NOT have requirements.
- D) In all cases of any doubt, or dispute arising regarding the compliance of any vehicle with these Regulations, or the eligibility of any vehicle for any class, the onus shall rest with the competitor to prove compliance, or eligibility.
- E) **TYRES**

C Class - Maximum tyre size for Super Modified Vehicles will be 35" x 14.5" or metric equivalent as per manufacturers specifications or as marked on tyre wall.

D Class - Maximum tyre size for Super Modified Vehicles will be 35" x 14.5" or metric equivalent as per manufacturers specifications or as marked on tyre wall
- F) Super modified vehicles may have any form of modification to, or transplant of the following:
 - a) Body
 - b) Chassis
 - c) Engine
 - d) Cooling System
 - e) Gearbox and/or transfer case
 - f) Clutch
 - g) Ignition System
 - h) Fuel System
 - i) Steering
 - j) Exhaust
 - k) Differentials
 - l) Brakes
 - m) Suspension
 - n) Rims
 - o) Electrical System
 - p) Seats
- G) Super Modified vehicles may modify or remove any other parts, fittings, or accessories not listed above, provided the vehicle complies with all other requirements of these Regulations.

7.3 **SUPER PRODUCTION VEHICLES – CLASS E AND F**

Following the 2007 AGM, all vehicle class rules can only be changed by remit every third year.
ie: 2022. 2025

- A) A Super Production Vehicle is as it leaves the master distributor's factory, and must use original equipment and parts for the vehicle make, and model, except as expressly permitted, or disallowed, in the requirements of this Section 7.3.
- B) Super Production Vehicles must exceed fifty fully built up units of the same make and model or public sale by the master distributor.
- C) Any competitor who deliberately enters a Super Production Class Vehicle with any modification other than permitted in these Regulations, will lose all points gained, and be banned from competing in the rest of the Series.
- D) In all cases of any doubt, or dispute arising regarding the compliance of any vehicle with these Regulations, or the eligibility of any vehicle for any class, the onus shall rest with the competitor to prove compliance, or eligibility.
- E) If required, the competitor must supply a set of factory specifications for the vehicle make, model, and year, for Super Production Class vehicles
- F) Compliance with section 6, MUST have requirements.
- G) Compliance with section 6, MAY have requirements, and:
 - i) Factory gauges and gauge panels can be replaced provided replacements fit within the original factory dash.
- H) Compliance with section 6, MUST NOT have requirements.
- I) **BODY**
 - a) On all vehicles the top may be removed i.e.: roof, side panels, pillars, tops of doors, windscreen, and all glass down to the height of the windscreen base or to no lower than it left the Master Distributors factory as a soft top body. Where the body has been cut for the top to be removed, it shall be made safe by welding in covers to eliminate all sharp edges.
 - b) On all vehicles in addition to the above, tailgates, spare wheel carriers, footstep assemblies, rear seats (including belts), upholstery, trims and factory built roll bars may be removed.
 - c) Bumpers and bumperettes maybe lightened, altered, replaced with aftermarket bumpers or replaced with a rear bar.
 - d) Front (bull) rear, or side bars may be added.
 - e) Standard seats may be replaced with non-standard seats.
 - f) The body may be modified to allow the installation of any engine, gearbox, or transfer case, provided that floor and bulkhead/firewall panels are complete.
 - g) Original doors may be replaced with non-standard doors, or removed.
 - h) The bonnet may be modified to improve engine cooling, but must completely cover the engine bay.
 - i) Any modification to the wheel arch and inner guards (front and rear) can be made provided some form of inner guard made from similar material is in place and that it is ONLY done for tyre clearance. With no sharp edges left that can cause harm.
 - j) Panels made from materials not used in production assembly may be used provided the panels equal or exceed the original panel weight, and conform to the original design and shape, and it is proved that either:

- i) The body panels concerned are no longer available, e.g. Gipsy panels; Or
- ii) The body panels concerned are less expensive than the original panel. The panels concerned can be one piece design, eg. One piece fibreglass bonnet, guards and front grill.
- k) The front wheel inner guard and firewall may be modified to allow for suspension alterations as per rule 7.3 O) a).
- l) An area below the "B" pillar (top front corner) next to the seats may have up to 50cm² removed for occupant safety only. For example a triangle removed that is 10cm horizontally from the top corner of the panel to 10cm vertically below the top panel.



J) CHASSIS

- a) The chassis may be modified to allow for front tyre clearance, or for changing engine or gearbox/transfer case mounts, and such modifications shall be only those required to install another engine, gearbox or transfer case or to allow tyre clearance.
- b) Modifications to the chassis may be made to allow for front suspension modifications as per rule 7.3 O) (a)
- c) Front chassis rails may be shortened, provided all original body mounts on the chassis shall be untouched and as per original manufacturers specification.

K) DIFFERENTIALS

- a) Super Production modified vehicles may not have any form of locking devices or limited slip etc. in differentials or on axles, whether factory fitted or aftermarket.
- b) Differentials may be internally modified, and axles changed.
- c) Anti sway/roll bars may be removed from differentials.
- d) Standard differential assemblies may be replaced with any brand of factory made differential assemblies I.E. complete housing, head, and axles.
- e) An inspection hole of no greater than 75mm may be added to factory differential housings both front and rear.

L) SUSPENSION

- a) Any form of suspension modification may be made to the front of the vehicle.
- b) Rear springs and suspension must be factory design and specification for that year, make and model of vehicle & a rear single top link may be fitted to the rear differential. Note: original mounts MUST be used on donor differential housing.
- c) Factory suspension components may be replaced with aftermarket components that conform to the original manufacturers design.

M) TYRES

- a) E Class - Maximum tyre size for Super production vehicles will be 35" x 14.5" or metric equivalent as per manufacturers specifications or as marked on tyre wall.

F Class - Maximum tyre size for Super production vehicles will be 35" x 14.5" or metric equivalent as per manufacturers specifications or as marked on tyre wall.
- b) Any form of modification to rims is permitted.

N) BRAKES

- a) Super Production vehicles may fit brake boosters, tandem master cylinders, and/or disc brakes to the original brake system.

- b) Independent wheel brakes may be fitted to either the front or rear of the vehicle but not both.
- c) Discs and/or callipers may be added/replaced to improve braking efficiency.

O) CLUTCH

- a) Clutch plates, pressure plates, and release bearings may be replaced with aftermarket clutch parts.
- b) Clutch cables may be replaced with hydraulic clutch operation systems

P) SHOCK ABSORBERS

Super Production vehicles may fit heavy duty shock absorbers provided they are fitted to the original mounts, and equal the number of shock absorbers that were factory fitted. Replacement shock absorbers shall have an extended length no greater than 5mm longer than the factory specification. *(Interpreted if front suspension is modified as per 7.3.O a, then rear shock absorbers may be fitted as per this clause 7.3.S)*

Q) SPRINGS

Super Production vehicles may fit shackle stops, and overset springs may be used, provided they conform to the original design.

R) RIMS

- a) Track of wheel may be altered.
- b) Wheel spacers may be used.

S) FITTINGS AND ACCESSORIES

- a) The following items may be removed: emission control equipment, wiper arms, screen and headlamp washers, rear vision mirrors, sun visors, heaters and ducting, air conditioning, horns, clocks, radios, cigarette lighters, ash trays, centre consoles, cabin lights, inside door handles, window winder mechanisms, all associated wiring and equipment.

T) Super Production Vehicles may have any form of modification to, or transplant of the following:

- a) Engine
- b) Gearbox and/or transfer case
- c) Ignition System
- d) Fuel System
- e) Steering, except four wheel steering and orbital steering
- f) Exhaust
- g) Cooling System (Any form of modification can be made to the cooling system as long as the radiator remains securely mounted anywhere under the confines of the bonnet)
- h) Drive Shafts.

7.4 **PRODUCTION VEHICLES - CLASS G**

**Following the 2007 AGM, all vehicle class rules can only be changed by remit every third year.
ie: 2022, 2025**

- A) A Production vehicle is as it leaves the master distributor's factory, and must use original equipment and parts for the vehicle make, model and year, except as expressly permitted, or dis-allowed in the requirements of this Section 7.4.
- B) Production vehicles must exceed fifty fully built up units of the same make and model for public sale by the master distributor.
- C) Any competitor who deliberately enters an Production Class Vehicle with any modification other than permitted in these Regulations, will lose all points gained, and be banned from competing in the rest of the series.
- D) In all cases of any doubt, or dispute arising regarding the compliance of any vehicle with these Regulations, or the eligibility of any vehicle for any class, the onus shall rest with the competitor to prove compliance, or eligibility.
- E) If required, the competitor must supply a set of factory specifications for the vehicle make, model, and year, for Production Class vehicles
- F) Compliance with section 6, **MUST** have requirements.
- G) Compliance with section 6, **MAY** have requirements, and:
 - i) Factory gauges and gauge panels can be replaced provided replacements fit within the original factory dash.
- H) Compliance with section 6, **MUST NOT** have requirements.
- I) **BODY**
 - a) On all vehicles the top may be removed, i.e.: roof, side panels, pillars, tops of doors, windscreen, and all glass, down to the height of the windscreen base or to no lower than it left the Master Distributors factory as soft top body.
 - b) On all vehicles, in addition to the above, tailgates, spare wheel carriers, footstep assemblies, rear seats, and factory built roll bars may be removed.
 - c) Bumpers and bumperettes may be lightened, altered, or replaced with aftermarket bumpers.
 - d) Front (bull), rear or side bars may be added.
 - e) Standard seats may be replaced with non-standard seats.
 - f) Panels made from materials not used in production assembly may be used provided the panels equal or exceed the original panel weight, and conform to the original design and shape, and it is proved that either:
 - i) The body panels concerned are no longer available e.g: Gipsy panels; or
 - ii) The body panels concerned are less expensive than the original panels; or
 - iii) The panel concerned can be one piece design, eg. One piece fibreglass bonnet, guards and front grill.
 - g) Original doors may be replaced with non-standard doors, or removed.
- J) **ENGINE**

Engines may only be modified as follows:

 - a) Cylinder head may be planed, ported, and polished.
 - b) Internal engine components may be bored, balanced polished, and blueprinted.

K) FAN

Fans may be removed, or plastic fans replaced with metal fans.

L) IGNITION SYSTEMS

Ignition systems may only be modified as follows:

- a) Distributor may be internally modified.
- b) Coils, high and low tension leads, and wiring, may be replaced with non-standard parts.
- c) Ignition components may be waterproofed by using spray-on or other similar waterproofing treatments.

M) FUEL SYSTEM

- a) Vehicles must use the factory fitted fuel system, which may include turbo-charges, super- chargers, and/or petrol injection, but may not use aftermarket units except for the usage of aftermarket fuel pumps.
- b) Vehicles may move their fuel tank within the confines of the vehicle and/or replace their fuel tank with an aftermarket unit.

N) GEARBOX

- a) Vehicles may have factory fitted locking devices in transfer cases, e.g. Range Rover, Jeep, Niva.
- b) Gearboxes and transfer cases may be internally modified.

O) DIFFERENTIALS

- a) Vehicles must use factory fitted differentials, which may include locking devices, limited slip, etc., in differentials or on axles, but may not use aftermarket units.
- b) An inspection hole of no greater than 75mm may be added to factory differential housings both front and rear.

P) BRAKES

- a) Production vehicles may fit brake boosters, tandem master cylinders, and/or disc brakes to the original brake system.
- b) (**Not in effect till 2022-2023**) Independent wheel brakes may be fitted either to the front or rear of the vehicle but not both.
- c) Discs and/or callipers may be added/replaced to improve braking efficiency.

Q) CLUTCH

- a) Clutch plates, pressure plates and release bearings may be replaced with aftermarket clutch parts.
- b) Clutch cables may be replaced with hydraulic clutch operation systems.

R) SHOCK ABSORBERS

Vehicles may fit heavy duty shock absorbers provided they are fitted to the original mounts, and equal the number of shock absorbers that were factory fitted.

S) EXHAUST

Vehicles may have any form of modification to the exhaust system, but exhaust must be to WOF standard.

T) RIMS

Vehicles must use rims which are no wider than eight inches and no more than sixteen inches in diameter.

a) Wheel spacers must not be used.

U) TYRES

Maximum tyre size for vehicles will be 31" x 12.5" or metric equivalent as per manufacturers specifications or as marked on tyre wall.

V) FITTINGS AND ACCESSORIES

The following items may be removed: emission control equipment, wiper arms, screen and headlamp washers, rear vision mirrors, sun visors, heaters and ducting, air conditioning, horns, clocks, radios, cigarette lighters, ash trays, centre consoles, cabin lights, inside door handles, and window winder mechanisms.

7.5 SUPER LIMITED MODIFIED VEHICLES - CLASSES J & K

Following the 2007 AGM, all vehicle class rules can only be changed by remit every third year.
ie: 2022, 2025

- A) Section 7.5 A) Compliance with section 6, MUST have requirements.
- B) Section 7.5 B) Compliance with section 6, MAY have requirements, and:
- i) Vehicles may have mudguards
- C) Section 7.5 C) Compliance with section 6, MUST NOT have requirements.
- D) In all cases of any doubt, or dispute arising regarding the compliance of any vehicle with these Regulations, or the eligibility of any vehicle for any class, the onus shall rest with the competitor to prove compliance, or eligibility.
- E) TYRES
- J Class - Maximum tyre size will be 35" x 14.5" or metric equivalent as per manufacturers specifications or as marked on tyre wall.
- K Class - Maximum tyre size for super Modified Vehicles will be 35" x 14.5" or metric equivalent as per manufacturers specifications or as marked on tyre wall.
- F) DIFFERENTIALS
Super Limited Modified vehicles may have any form of modifications to differentials except as follows;
- a) Vehicles may not have any form of locking devices or limited slip etc. in differentials or on axles, whether factory fitted or aftermarket.
- b) Differentials assemblies may be replaced with any brand of factory made differential assemblies i.e. complete housing, head, and axles.
- G) BRAKES
- a) Super Limited Modified vehicles may fit brake boosters, tandem master cylinders, and/or disc brakes to the original brake system.
- b) Independent wheel brakes may be fitted to either the front or rear of the vehicle but not both.
- c) Discs and/or callipers may be added/replaced to improve braking efficiency.
- H) Super Limited modified vehicles may have any form of modification to, or transplant of the following:
- a) Body
- b) Chassis
- c) Engine
- d) Cooling System
- e) Gearbox and/or transfer case
- f) Clutch
- g) Ignition System
- h) Fuel System
- i) Steering, except four wheel steering
- j) Exhaust
- k) Suspension
- l) Rims
- m) Electrical System
- n) Seats
- I) Super Limited Modified Vehicles may modify or remove any other parts, fittings, or accessories not listed above, provided the vehicle complies with all other requirements of these Regulations.

Competition Committee SCRUTINEERING SHEET

Event Name:

Event Date:

Drivers Name:

Navigators Name:

Competition Licence No.:

| C O M P | P A S S | F A I L | R E C H | ITEM | CLASS | DRAW NO. |
|--|------------------|------------------|------------------|---|---------------------------------------|-------------------------------|
| | | | | Navigators Drivers Licences Sighted | Licences | Comments |
| | | | | Drivers "Drivers" Licences Sighted | | |
| | | | | Roll Cage/Mounts/Welds/tags – Support Structure | | |
| | | | | - Rollcage helmet clearance 100mm | | |
| | | | | Roof plate - truck weight: | | |
| | | | | - Design acceptable | | |
| | | | | - Thickness | | |
| | | | | Firewall | Chassis And Body | |
| | | | | Body/Chassis (secure) | | |
| | | | | Tow Hooks/Front and Rear/HT Bolts | | |
| | | | | Bonnet (secure) | | |
| | | | | Seats (secure) | | |
| | | | | Seat Belts Approved Type (secure) and installation | | |
| | | | | Knobs on Levers | | |
| | | | | Fire Extinguisher Approved Type/Test Date – SHAKE | | |
| | | | | Crash Helmet Approved Type/Condition | | |
| | | | | Rims Size | Wheels | |
| | | | | Tyres Approved Type/Size | | |
| | | | | Wheel Nuts and Studs (secure) | | |
| | | | | Foot Brake Operation | Brakes | |
| | | | | Brake Hoses and Pipes (no defects) | | |
| | | | | Battery (secure) | Electrical | |
| | | | | Fuel Tank/Lines/Non Leak Fuel Cap (secure) | Fuel | |
| | | | | Engine/Transmission Mounts (secure) | Engine | |
| | | | | Extra Throttle Spring (to carb butterfly) | | |
| | | | | Cooling Fans/Drive Belts (shroud protection) | | |
| | | | | Adequate Exhaust System (protected) | | |
| | | | | Drive Shafts/Universals (secure) | Drive and Suspension Components | |
| | | | | Steering Box/Rack System (secure) | | |
| | | | | Steering Joints and Hoses (no defects) | | |
| CHECK LIST FOR: Non C & D Classes. @ Delete for G Class, * Delete for A & B Class, # Delete for E & F Class, % Delete for J & K Class | | | | | | |
| | | | | % Correct Body | SCRUTINEER ING PASSED | |
| | | | | #*% Correct Engine | | |
| | | | | #*% Correct Transmission | | |
| | | | | #*% Correct Brake System | | |
| | | | | #% Correct Front Suspension | | |
| | | | | % Correct Rear Suspension | | |
| | | | | #% Front Springs and Shock Absorbers | | SCRUTINEER 'S SIGNATURE |
| | | | | % Rear Springs and Shock Absorbers | | |
| | | | | #% Front Shackles and Bushes | | |
| | | | | % Rear Shackles and Bushes | | |
| | | | | @ No LSD, SRD, or Diff locking Devices | | |
| | | | | #*% Inside Track Measurement | | |
| | | | | @* Independent wheel brakes one end only | | |
| | | | | | | |



SECTION EIGHT - COURSE

- 8.1 A) In planning a course, attention MUST be paid to the following:
- a) Select as great a variety of types of ground as possible.
 - b) A minimum of 25 observed sections, excluding timed sections shall be set.
 - c) With the exception of timed sections, a minimum of half of the remaining observed sections in any course shall be graded.
 - d) Approaches to, and exits from sections must not present any unreasonable danger or difficulty.
 - e) Competitors must be able to at least reach the start of each section.
 - f) In any National/Zone event there shall be at least one timed observed section.
 - g) All pegs shall be a minimum of 20mm alkathene hollow section pipe with relevant colour.
- B) Alternative access ways are to be planned in case of changes in weather or ground conditions.
- C) All escape routes (by-passes) if available must be clearly marked on the course.
- D) The use of earth moving machinery is allowed to create or alter sections. Foreign objects cannot be placed into the section. Only natural ground can be altered.
- E) Reversing sections are not permitted, (i.e. this means any section you are required to reverse as part of the section).

8.2 ALL SECTIONS

- A) The start of an observed section shall be indicated by Blue Pegs.
- B) a) The boundaries of an observed section shall be indicated by Red Pegs on the right, and Yellow Pegs on the left, or by natural obstacles marked with the appropriate colours.
- b) The boundaries of all observed sections shall be a minimum of 4.0 metres apart. This is to be measured by line of sight.
- c) The boundary pegs shall have a minimum height of one metre above the surface (ground, mud, water, etc.) of the section throughout the event.
- e) Touch pegs - Red or Yellow with Green tops - alkathene, may be used as boundary pegs on non-graded sections.
- C) The finish of an observed section shall be indicated by Blue Pegs.

8.3 GRADED SECTIONS

- a) Graded sections shall be divided into sub-sections, with a minimum of three gradings (sub-sections) per section.
- b) The end of each sub-section shall be marked by a grading marker, or sign, indicating the points applicable to that sub-section.

8.4 TIMED SECTIONS

- A) At any event a maximum of four observed sections may be timed.
- B) All timed sections are subject to the following conditions:
- a) Timed sections shall be no longer than 500 metres in length.
 - b) That no sections of an arduous, dangerous, or demanding nature are used, i.e. only those sections which can be completed without other than timed penalty by all classes, and the majority of competitors, may be timed.
 - c) The finish of a timed section may have a flying finish or a “garage” with the four corners marked by Blue Pegs.

8.5 WATER SECTIONS

All water sections are subject to the following conditions:

- a) Water sections must be less than 600mm in depth at course inspection and must be under 800mm in depth when being attempted.

Any sections involving water must:

Not do so in or nearby any flowing waterway where debris created by the section should enter this waterway.

Where flowing waterway is present on a course, reasonable steps should be taken to prevent sediment from entering the flowing waterway. This may involve, excluding high risk areas by taping off access, use of sediment filters at entry points, creating sediment bunding.

Where a flowing waterway is needed to be crossed to gain access to obstacles, efforts should be taken to do so without entering waterway. Temporary bridging, adding culverts etc should be considered.

This rule does not include 'bog' obstacles where the surface water may pool in wheel ruts, however if this becomes a significant safety hazard then course officials may close the obstacle.

8.6

Static stop / Sudden Stop

Description

A Static stop / Sudden stop is created by the design of a section that doesn't allow for two forms of directions of movement when jumping, rolling or driving forward

Types of Static stops / Sudden stops:

Jumping-

Identified risk--Situation were the lip at the top of a hill is vertical or with a turn back- This creates a situation were the vehicle and its occupants could be pushed to jump directly skywards and land with no forward momentum, so you have a pan cake landing were the vehicle lands stationery and compression of suspension will be maximised.

Risk with a pan cake landing-

1/ The suspension compression is so severe that the shocks go to full pump and some vehicles have little or no hydraulic stops this can cause spinal and neck injury when suspension bottoms out

2/ The suspension compression on landing reduces the frame/ body height distance off the ground, this can reduce chassis rail ground clearance in the centre of the truck to 200mm in some cases from the ground. If by any chance the centre of the chassis encounters the ground before the suspension has finished its cycle the occupants will bear full impact shock loading which may cause Neck and spinal injury through impact compression

3/ The Pan Cake landing could be on an uneven surface which could cause extreme whiplash

These situations can very much reduced if there is

1/ The top lip on the hill face is reduced

2/ Speed cannot be carried onto the face of the hill where the lip is situated

3/ you create a turn to the left or right at the very top of the hill to reduce the chance of people carrying speed onto the lip face

4/ The ground in the landing area is on the downhill face

5/ The ground in the landing area is smooth

Direct impact Front/ Roof

Identified risk--Situation where an approach to a vertical bank has zero lead in or run on to the vertical bank where the approach is at speed of 5km/h or more?

OR

The vehicle and its occupants have the potential to attempt to jump across a ditch or road and if they were to fail the impact could be on the vertical face on the opposing bank. This includes speed sections were if organisers are wanting to see vehicles and occupants jumping. In this situation a down ramp or run off should be provided on the landing side to ensure two forms of movement are carried. There should be no jumping of a road or ditch where there is potential for front impact into an opposing bank

It is important to remember at this point in our sport vehicles are not designed to be jumped at speed and the potential for a nose in on landing or a flat on roof landing could cause a static sudden stop with chest and neck injury's

These situations can very much reduced if there is

1/ A turn onto the vertical face, I.e., left- or right-hand approach onto the vertical face

2/ If there is a hill climb leading up to the vertical face pushing load onto rear wheels

3/ The surface is slippery

4/ Speed is reduced by the design of the approach

Rolls

Roll over were the vehicle and its Occupants could come to a sudden stop / Static stop on roof wheels or side suddenly/ quickly, this can cause neck, spinal and other body injury's

These situations can very much reduced if there is

1/ Make sure there are no Trees/ obstacles including opposing banks in the path of the roll that would stop the vehicle suddenly

2/ Room to drive out of a potential roll, so preventing the roll all together

3/ The section is designed so any potential roll is sideways rather than nose to tail

Nose to tail have the potential for high injury due to suspension compression pan cake landing and roof landings no suspension give.

SECTION NINE - COMPETITION

9.1 TRIALS RULES

- A) a) Competition Drivers Licence number issued for the season becomes Drivers Vehicle number for the season.
 b) Vehicle Numbers must be clearly displayed on each side of the competition vehicle throughout the event. The vehicle number first, followed by the class letter (e.g. 999C),
 Minimum 100mm in height and 15mm brushstroke.
 Vehicle Numbers must be in contrasting colour to background so clearly visible.
- B) a) Organisers shall advise competitors of the order in which they will start at their first observed section.
 b) Competitors will maintain their start order unless forced to a temporary retirement due to mechanical failure, or requirement to be checked after roll over, or as directed by the Clerk of the Course.
- C) a) There will be a multiple start.
 b) The Organisers shall determine the order of running of each observed section.
 c) The Organisers shall specify the time at which competitors must report to the start of their first observed section.
- D) There will be no time schedule to maintain except as below:
 a) Competitors will proceed from section to section with as little delay as possible.
 b) Any competitor suspected of loitering will be ordered to proceed by the Officials.
 c) Competitors arriving at an observed section more than 30 minutes after the preceding competitor may not be permitted to attempt that observed section, unless directed to by the Clerk of Course or a Steward.
 d) Competitors must hand in their score cards within 20 minutes after completing their final observed section, or if they retire from the event.
- E) a) Once the course has been set and approved by the Stewards, there shall be no changes to any section, or any sections added, or removed, except sections may be removed when closed for safety or other reason **(except 9.1 E) e)** by order of the Stewards or the Clerk of the Course. Any number of sections can be closed on the day of the rally.
 b) The onus on following the correct route shall rest with the competitor.
 c) No competitor shall attempt any one observed section more than once, unless specifically instructed to do so by the Clerk of the Course.
 d) If a section is closed by the Stewards or the Clerk of the Course, no performance by any competitor on that section shall be counted in the results.
 e) Once the first vehicle has attempted a section, it cannot be closed due to incorrect initial peg placement; Stewards **or the Clerk of the Course** may only close a section for safety reasons.
- F) a) No outside assistance is permitted on observed sections.
 b) Vehicles must complete the course, and proceed from section to section, under their own power.
- G) Competitors may inspect the course, usually, on the day prior to the event, unless the Information Sheet, states that an inspection of the course is unavailable, and the reason for no inspection being available.

- H)
 - a) Organisers have the right to add to these Regulations by issuing written Additional Supplementary Regulations (ASRs) but may not delete any of the Regulations.
 - b) Additional Supplementary Regulations (ASRs), if issued, may be sent to all competitors, but at the latest, will be handed to competitors at Scrutineering.
 - c) Any matters which arise after the issuing of ASRs will be advised to competitors at a Drivers' Briefing to be held immediately prior to the start of the event.
- I)
 - a) Competitors must compete in the vehicle they presented at scrutineering throughout the entire event.
- J) Any competitor or competitor's supporter seen trying to negotiate or argue points given to another competitor or followed competitor in any section with the Marshall or Marshalls may face penalties if both Stewards and/or the E.N.C.C. feel fit to do so.
- K) Score cards must be handed into the scorer or scorers helpers when returning to the pits during the event, your card can be collected as you exit the pits.

9.2 CREW RULES

- A) The crew shall not be varied during the event except:
 - a) The co-driver may drive in any or all observed sections, provided he/she holds a Competition Drivers Licence.
To retain points towards any championships, the driver must drive in at least three quarters of the sections set at any event.
 - b) The co-driver may be changed, provided always that the new crew member is an affiliated NZFWDA member, and that they hold a minimum of a Day Licence, and that the Entry Form and Indemnity have been signed.
 - c) The Clerk of the Course must be notified and give approval, before driver and co-driver change position, or any changes to the crew are made. Stewards are also to be notified prior to any crew changes so a safety check can be completed for new occupant (e.g. helmets, roll cage clearance and seat belt check).
- B) Only one passenger (co-driver) must be carried on the vehicle during observed sections, and that co-driver shall remain seated beside the driver throughout all observed sections.
- C)
 - a) Both driver and co-driver must be properly seated while the vehicle is negotiating a section.
 - b) Bouncing will be permitted only within the confines of the seating compartment, and then only so long as no portion of either the driver's or co-driver's body (other than arms and hands) is placed outside the seating compartment.
 - c) All competitors must wear seat belts while the vehicle is negotiating a section.
- D) All competitors must wear crash helmets with straps firmly secured while the vehicle is negotiating a section.
- E) Fire protective clothing, it is compulsory that all competitors wear fire resistant or fireproof undergarments or overalls to cover your body from your neck to your ankles. This can exclude your head, hands and feet. Fire protective clothing is defined as "garments made from purpose designed fabrics with 'built in' self-extinguishing properties". Fire retardant overalls are acceptable. The material must be identified on the manufacturers' label. These can include Nomex, Carbon X, Proban, ProTek, Pyrovatex, Aramid fibres or certified to standards FIA 8856-2000, FIA 8856-2018, SFI 3.2A/5 (race suits), SFI 3.3A/5, or a CAL rating of 19. Competitor can stack layers to achieve required ratings e.g. a single layer suit to SFI 3.3A/3 + under wear of SFI 3.2A/1 gives same level of protection.

- F) It is strongly recommended you do not wear any flammable clothing such as PVC over top of your fire protective clothing.
- G) Where no windscreen is fitted, or it has been broken, it is recommended that competitors wear goggles, or a helmet visor, sufficient to protect the eyes.
- H) a) Smoking is prohibited while negotiating any section
 b) Firearms may not be carried during any event.
 c) The use of drugs or alcohol in any form is prohibited during any event.
- I) a) i. All competitors must act in a fair and sportsman like manner.
 ii. All competitors must follow the instructions of the Clerk of the Course and Stewards running the trial.
 iii. Competitors shall not, at any time, act in such a manner or cause any action to be taken that shall bring the Sport, the Event, the Association or the Competitions Committee into disrepute.
- b) Any competitor found to be cheating or to be in breach of or abusing these Regulations may be issued a penalty by the National Competitions Committee Executive.

The penalties available to the National Competitions Committee Executive shall include:

- i 200 point section penalty.
 ii Allocation of penalty points for the trial.
 iii Banned from competing in the trial at which the offence took place.
 iv Loss of placing points for the trial at which the offence took place.
 v Loss of placing points and/or banned for a set number of events
 vi Loss of placing points and/or banned for the current Season/Series.

9.3 SECTION RULES

- A) a) Before attempting an observed section, vehicles will be brought to rest with the leading wheel hub centre vertically over the start line, as indicated by the Officials, and the driver shall not proceed until instructed to do so.
 b) A vehicle will be deemed to have entered an observed section when the leading wheel hub centre is past the blue pegs at the start of that section.
 c) Failure to proceed, whether involuntary or otherwise, from the start position into an observed section when instructed to do so, will be regarded as failure in that section.
 d) Competitors **MUST** be ready to start a section as soon as possible after previous vehicle.
- B) Competitors will attempt to negotiate observed sections non-stop.
- C) a) Failure of a vehicle to maintain unassisted motion in the direction of the course, will be regarded as failure to comply with the requirements to proceed non-stop.
 b) The point of failure will be when the hub centre of the leading wheel which is furthest from the start of the section, passes a sub-section marker or grading peg.
 c) In a timed section, failure of a vehicle to maintain unassisted motion in the direction of the course shall not be regarded as failure. Further attempts to complete the section shall be permitted until the maximum time allowed has elapsed.

- D) a) A vehicle will be deemed to have⁴⁸ completed an observed section when the leading wheel hub centre is past the blue pegs at the end of that section, provided that no prior penalties have been incurred.
- b) Failure in an earlier, or lower sub-section will constitute failure in all succeeding sub-sections.

- c) In a timed section, a vehicle will be deemed to have completed the section when all four wheels are past the blue pegs at the end of that section, or when the vehicle stops with all four wheels inside the “garage” formed by four blue pegs. Reversing into garage will be allowed.

- E) A competitor will be deemed to have failed to negotiate a graded section when:
 - a) Any part of the competitors vehicle flattens, straddles, or runs over a boundary peg.
 - b) All four wheels of the vehicle cross the boundary of the course.
 - c) The point of failure will be deemed to be when the hub centre of the leading wheel is furthest from the start of the section when a boundary peg is flattened, straddled, or run over, or at the point where the boundary of the course is first crossed by all four wheels of the vehicle.
 - d) Should the point of failure coincide with a division between sub-sections, the points lost will be those appropriate to failure in which ever sub-section provides the greater penalty.

- F)
 - a) A competitor will be deemed to have failed to negotiate a non-graded section when all four wheels of the vehicle cross the boundary of the course.
 - b) In a timed section, provided the vehicle re-enters the section before the next boundary peg, this shall not be regarded as failure.

9.4 SCORING

- A) NZFWDA Score Cards will be issued and completed as follows:
- a) A driver's score card to each vehicle.
 - b) A marshal's score card to each observed section.
 - c) Both the driver's and the marshal's cards will have points gained entered by pen as appropriate to media used.
 - d) When no penalties are incurred, zero or nil shall be entered on the score card. Do not use "O".
 - e) The competitor and the marshal shall sign each other's card after entry of the score by the marshal.
- B) Competitors will start with zero points. The competitor incurring the lowest number of points will be the winner, next lowest points - second and so on down.
- C) No case of "force majeure" (an unforeseeable course of events beyond your control) will be taken into consideration.
- D) The start pegs will indicate the greatest penalty, and the finish pegs the least penalty.
- E) Penalties will be incurred as follows:
- a) Not attempting, or not being ready to attempt an observed section 200
 - b) Blue pegs at start of any section flattened, straddled or run over 100
 - c) Failure in an observed section when divided into sub-sections, such penalty as denoted on the sub-section marker 100 Maximum
 - d) Red or yellow pegs in a graded section flattened, straddled or run over Value of grading sign just passed
 - e) Red or Yellow pegs in a non-graded section flattened, straddled or run over 20 each peg to 100 maximum
 - f) Touch pegs in a non-graded section touched, flattened, straddled or run over. 20 each peg to 100 maximum
 - g) Blue pegs at finish of graded section flattened, straddled or run over. value of grading sign just passed
 - h) Blue pegs at finish of non-graded section flattened, straddled or run over 10
 - i) Successful negotiation of a timed section within the time allowed O(zero or nil)
 - j) Successful negotiation of a timed section in excess of the time allowed 1 point per second over time allowed to 100 maximum
 - k) Red, Yellow or Blue finish pegs in a timed section flattened, straddled, or run over - penalties as for non-graded sections, (e) and (h). added to any time penalties incurred to 100 maximum
 - l) Not wearing crash helmets or seat belts in an observed section 200
 - m) Not complying with instructions of an Official, after receiving a warning 200

9.5 POINTS

- A) Events will be scored on a Class Basis, with placings declared in each Class and Overall
- B) National/Zone Series points will be awarded to drivers who have deemed to be finishers in each Class and Overall from 1st place down: 100, 99, 98,97, 96, 95, 94 etc.
- C) To be classed as a finisher, a driver must have completed at least three quarters of the total number of observed sections run at any event, arrived at their final observed section within 30 minutes of the preceding vehicle (*unless directed to by the Clerk of Course or a Steward*), and handed in their score card within 20 minutes after completing their last observed section.
- D) Removed at AGM 2018
- E) Zone Series points will be allocated to drivers competing in their Zone of residence. If a person belongs to Clubs in more than one zone, he/she shall nominate at the start of the series which Zone Series they wish to gain points in.
- F) Removed at AGM 2018

9.6 TIES

- A) In the event of a tie for any position in an event, the winner of that position shall be determined by reference to performances of the tied drivers in predetermined observed sections as selected under SECTION TWO, 2.3 D).
- B) In the event of a of a tie for a position in the final scoring of a National/Zone Series, the winner of that position shall be determined by re-adding the seasons scores including any dropped rounds (Refer Section one, 1.4 A)
 If this does not resolve the tie then the winner of that position shall be determined reference to the tied drivers' greater number of superior positions in all the events of the series. Being the greater number of firsts, then seconds, then thirds, and so on, including DNF but not DNS. If one driver has a First and the other driver doesn't, then the count back stops and that driver is determined to be the winner, if not, then seconds and so on...
- C) If the provisions of 8.6 A) and B) do not break the tie, the position shall be declared equal - the drivers equal winners of that position. The following placings shall follow in order, i.e.: first equal, then third, and so on

SECTION TEN - PROTESTS AND APPEALS

10.1 PROTESTS

- A) Protests against the scoring of any section are to be advised to the Marshal of that section who shall mark both the driver's and the Marshal's score cards with a "P" next to that section.
- B) All protests must be advised to the National Scorer, and a \$20.00 Protest Fee paid, when the driver hands in the score card, within 20 minutes of completing the final observed section. It is advisable that protests are in writing.
- C) The National Scorer shall notify the ENCC of all protests received.
- D) The ENCC shall convene the Protest Committee, who shall consider the protest, and call on whoever may assist in determining the matter, to give evidence.
- E) In any protest against another competitor, or an official, that competitor or official shall be notified of the protest, and given the right to be heard on the matter, before any decision is made.
- F) The protester shall be notified of the decision of the Protest Committee before this decision becomes final.
- G) Any competitor, or official who has been protested against, shall be notified of the final decision of the Protest Committee before that decision is announced.
- H) At any National/Zone event, no further protests will be accepted after the announcing of the Protest Committee's final decision on any matter.
- I) If any protest is upheld, the \$20.00 protest fee shall be returned to the protester.
- J) Protests on the results displayed must be advised to the National Scorer before the results become the Provisional Results.
- K)
 - a) Only protests regarding the addition of scores shall be accepted, and no protest fee is required.
 - b) The National Scorer shall check the additions, and amend the results, if necessary.

10.2 APPEALS

- A) Appeals against any final decision of a Protest Committee, or any other matter relating to any event, must be made to the Executive of the National Competitions Committee within 14 days of any final decision, or ruling, or interpretation being given or made.
(refer NZFWDA Constitution, Rule 31, Right of Appeal)
- B) When an appeal is received by the ENCC the N.C.O. will convene and chair an Appeal Committee. This committee will be chosen by a random draw of ten competition licence holders who shall have one vote each. The N.C.O. will give these ten, all information relevant to the appeal. The competitor shall have the right to put in writing, their argument, which shall be presented to the appeal committee, with no modification or censoring of the content. A meeting will be arranged with 14 days notice given. The proceedings will be confidential with only the appeal committee members knowing the identities of the members. The Appeal Committee will appoint their own spokesperson who will pass their decision to the Executive of the National Competition Committee. If a meeting is not practicable, a telephone conference, or postal ballot will be permitted. Majority decision will be final. The N.C.O. will co-ordinate and chair the appeal committee and process the decision but will have a casting vote only.

SECTION ELEVEN - LOG BOOK

- A)
 - a) A vehicle Log Book will be issued at the first scrutineering of any vehicle, and is to be retained, kept safe, and presented with the vehicle at scrutineering of each event entered.
 - b) A new master record log book will be purchased by the secretary at the start of each season to be used by the scrutineers.
 - c) A register of all log books given out shall be kept by the Secretary.

- B) The Log Book is retained by the vehicle owner, and if/when the vehicle is sold, passes to the new owner with the vehicle, and ownership details are updated in the Log Book.

- C) Replacements for lost Log Books will cost \$5.00.

- D) The Scrutineer shall complete the scrutineering details in each Log Book at each event entered, and keep a Master Record of all Log Book details.

- E) The following details must be included in Log Books, and the Master Record:

- F) Information recorded in log book
 - (a) Information required to prove eligibility, - can compete in trial but no compliance can't compete in next trial until provided.
 - (b) Modification required to comply with rules - can't compete in trial, but can change class until mod has been done.
 - (c) Safety - must be fixed or sorted before start of trial.

NEW ZEALAND FOUR WHEEL DRIVE ASSOCIATION Inc (logo)

COMPETITION VEHICLE LOG BOOK

Log Book No. Original / Continuation / Replacement

RECORD OF OWNERSHIP

| Date | Name | Address |
|-------|-------|---------|
| | | |
| | | |

VEHICLE SPECIFICATIONS

Vehicle Make: Model: Year:

Chassis No.: Rego No.:

Engine Make: No. of Cylinders: CC Rating:

Fuel Type: PETROL DIESEL LPG (circle)

Class: A B C D E F G J K (circle)

MODIFIED

| Date | Host Club | Pass Fail | Scrutineers Signature | Defects to be Remedied Before Next Event |
|-------|-----------|-----------|-----------------------|--|
| | | | | |

NZFWDA COMPETITION LICENCE APPLICATION



Please Print clearly and Tick appropriate box

Please be aware that licence fees will double the price two weeks before each Trial

Drivers Licence
\$140.00
DL No..... (driver)

Navigators Licence
\$70.00
NL No..... (co driver)

Day Driver's Licence
\$70.00
DL No

Vehicle No:..... (If relevant)

Full Name:

Ph:

Address: Postal:

.....

email: Please indicate preferred way info received

Date of Birth (if under 18): E-mail Post

Current Driver Licence No NZ Drivers Licence (to be sited upon request)

Category (circle) Full Restricted Learners

Club: Position:

Club Official's Name: Club Official's signature

Club Official is signing to acknowledge that applicant is a member of Club and has the ability & knowledge to compete in the National Series

NZ4WDA EMERGENCY NAVIGATORS LICENCE APPLICATION

Licence Fee \$50.00 DY

Name: Trial entering

Address:

Phone Number: Vehicle no.:

Club: Affiliation Number:

Drivers Licence No: Class:

Proof of current NZ Drivers Licence and Affiliation Number must be attached or presented upon issuing of licence.

Email:

Send to The Treasurer- Competitions Committee Phone:

Cheques Payable to: NZFWDA Competitions Committee or Direct Credit using initial and surname as reference and email Treasurer then post form:
060541 0126044 00 National Bank

